

2024 | AIR CONDITIONER

2024
AIR CONDITIONER
LG HVAC Solution



LG Electronics

<http://www.lg.com>
<http://partner.lge.com>

Distributed by



EUROPE SALES INFRASTRUCTURE

-  Europe B2B Regional Head Office
-  National Sales Office
-  Air Conditioning Academy
-  European Distribution Center
-  Europe Energy Lab
-  Production Site



GLOBAL PRODUCTION SITE



LG Energy Labs in Europe

LG Energy Labs are driven to fulfill the commitment of meeting all the requirements regarding energy efficiency and environmental demands. Each LG Energy Lab is an innovative site dedicated to provide essential commercial and residential products in heating, ventilation and the latest energy efficient air conditioning solutions. Additionally, as a showcase, the LG Energy Lab is equipped with complete monitoring and control systems. The performance of all products are tracked and analyzed by a team of Research and Development engineers based in France, Finland and Korea, ensuring maximum efficiency and reliability during the complete products' lifecycle.



European Air Conditioning Distribution Center

LG's European Air Conditioning Distribution Center is centralised in Oosterhout, the Netherlands. Supplying and delivering products to 15 countries in Europe, this Distribution hub has contributed to quick and seamless delivery, direct shipping for smaller orders and bespoke delivery to air conditioners. The hub tries to manage inventory efficiency by complying with the LG EU's established inventory pool.

TOTAL HVAC SOLUTION PROVIDER

Since manufacturing Korea's first air conditioner exclusively designed for residential use in 1968, LG has been a pioneer of air conditioning innovation. Encouraged by LG's technological leadership in the residential air conditioning sector since the late 1990s, LG moved into the commercial air conditioning sector.

LG has established itself as an exemplary HVAC and energy solutions provider, investing in new technologies, with the addition of chiller, VRF systems and building management systems (BMS) to its comprehensive product portfolio. Alongside its wide range of innovative solutions, the LG promise is to deliver unparalleled customer service.

LG produces expert air conditioning professionals at its academic centers, of which there are nearly 80 worldwide. These academic centers provide workshops and training programs that offer excellent hands-on experience. Additionally, LG provides advanced and highly sophisticated tools for HVAC system engineers and installers, including its time saving LG Air Conditioner Technical Solution (LATS) software. LATS allows LG to support clients with draft energy estimation and energy modeling, model selection and design, lifecycle cost analysis and more to ensure a seamless process from planning to execution. LG also operates several state-of-the-art R&D facilities all across the planet.

Made Better with ThinQ™

With most people living lives that are more hectic than ever before, we see the enormous potential benefits new technologies will bring to the home. ThinQ links smart products together so that they can work in unison to make your home smarter and more connected. New levels of control and convenience simplify everyday life and free up time so that you can stay focused on what matters. Furthermore, transformative features and services with artificial intelligence will take home evolution one step further. ThinQ will provide more personalized and optimized solutions by learning your needs and preferences through its wide range of products. Get more done while doing less. ThinQ's Personalized Solution, Proactive Advice, Maximum Efficiency and Intuitive Control deliver an elevated, more intelligent lifestyle.

LG ensures its intelligent offerings, AI-powered products and services unlock new roles for homes that can play an important role for truly smart living. Think Wise. Be Free.

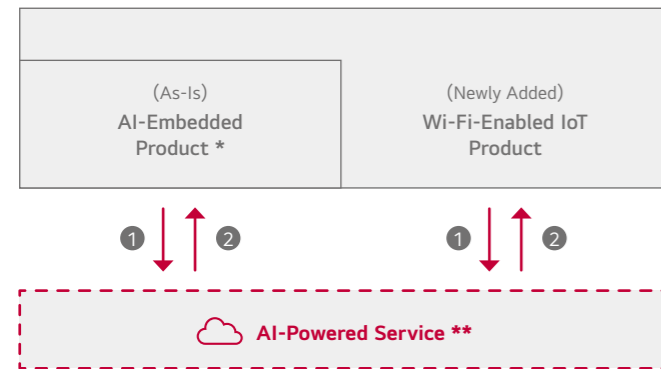

- ① Understanding users via data collection
- ② Providing tips & solutions through AI data analytics

* Previous ThinQ products-Requirement : evolving products with vocal/visual/product intelligence
 ** Examples of AI-Powered Service : -Usage guide/tips, Predictive maintenance, Auto/semi-auto setting (TBD)

Consumer Benefits

Intuitive Control
 ThinQ adds convenience to your daily life by simplifying daily tasks. The ThinQ experience is reliable, flexible and effortless from setup to control and beyond. ThinQ products can be controlled from anywhere and at any time with simple voice-commands and a tap of the innovative ThinQ smartphone application. Meaning anywhere can be your home.

Maximum Efficiency
 ThinQ minimizes energy consumption and can even track your energy usage and expenditure. Beyond mechanical advancements, ThinQ provides unrivaled energy efficiency by utilizing a combination of analytics, sensors and usage data.

“
ThinQ:
A Brand for Products and
Services Incorporating
Advanced AI Technologies
 ”





192

192 ~ 407

COMMERCIAL

Single split	194
Chiller	344

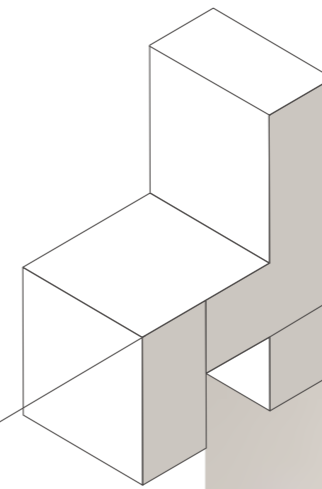

008

008 ~ 191

RESIDENTIAL

Wall mounted	020
Ventilation	070
Multi split	076



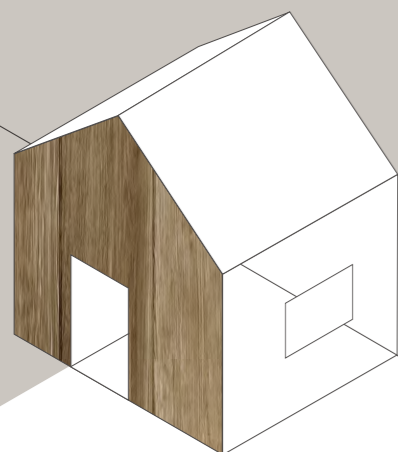

008 ~ 191

RESIDENTIAL

Wall mounted

Ventilation

Multi split



Soft Air Surrounds You In Comfort

LG DUALCOOL™

Premium / Deluxe



Why LG DUALCOOL™?



Comfortable Air Flow

Enjoy a perfectly balanced breeze through multiple vanes and indirect air flow. Stay refreshed with automatic dehumidification matching your desired temperature. "Enjoy a Perfectly Balanced Breeze and Ideal Humidity, Tailored Just for You."



Proactive Energy Saving

Avoid worrying about unexpected electricity bills with kW manager. Human detecting sensor and window open detection actively save energy without having to worry about it.



Total Air Care

A multi-step filtration process with Freeze Cleaning that purifies the air, removes dust and bacteria, ensuring the air you breathe is always fresh.

Key Feature

Soft Air

Stay comfortably cool with no chilly drafts and personalize breeze range and temperature.

※ When connected Multi ODU, soft air function may not be supported.

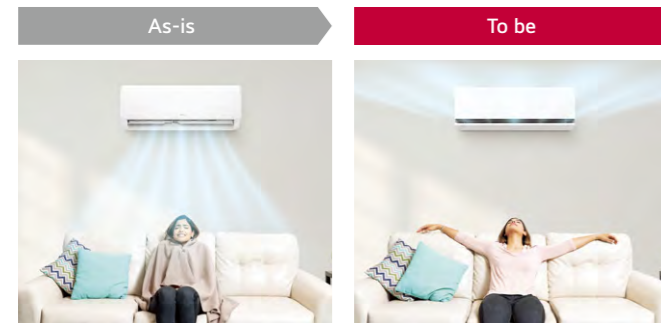

When turned on, it becomes too cold, and if turned off, it becomes too hot. Additionally, when lying down on the bed, the direct cold wind can quickly make you feel uncomfortably cold.

Experience a shift from excessive cold to a more comfortable and pleasant airflow—a fine-tuned wind flow for your comfort.

Comfortable Air Flow

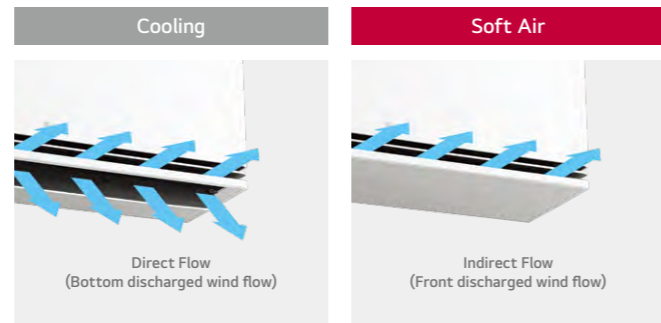

Cooling
Room Temp. Control
→ Always cold wind

Soft Air
Wind Temp. Control
→ A pleasant, comfortable wind

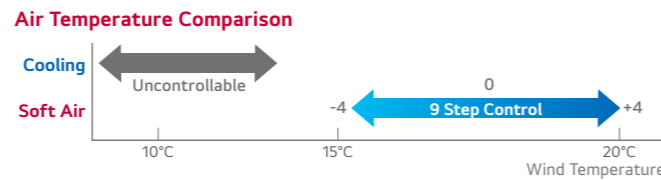
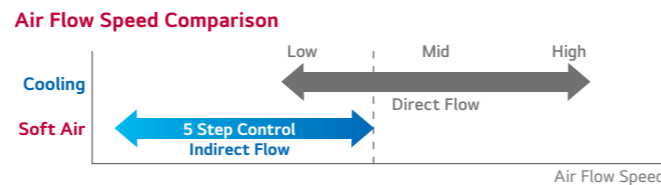

※ This function can be applied Cooling / Fan mode only.
 ※ Wind temperature can be controlled through remote controller or LG ThinQ app.
 ※ Setting room temperature can be controlled through LG ThinQ app only.
 ※ The wind temperature is displayed on the remote controller only in step (-4 to +4), and the temperature is not displayed.
 ※ This feature is available when the indoor temperature is below 28°C.

Comfort Humidity Control

No excess chill, Comfort Humidity Control perfects your home with humidity optimized to your desired temperature.

Comfortable Air Flow

Conventional



LG DUALCOOL

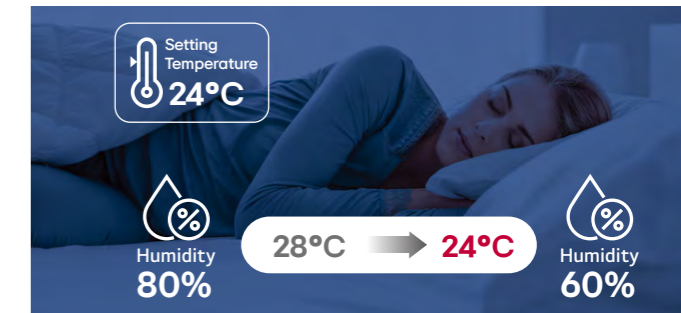

Operation Example (24°C Setting)

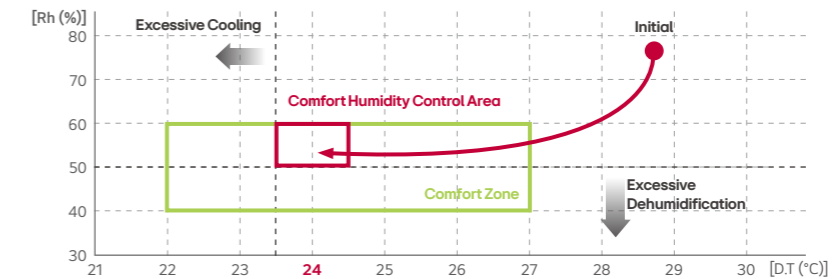

※ The air flow changes automatically based on the operating environment.
 ※ This function can be used through remote controller and LG ThinQ app.
 ※ The humidity is automatically controlled according to the temperature set by the customer.

DUAL Vane

Dual Vane spreads airflow up or down, further and faster, for ideal comfort in any season.

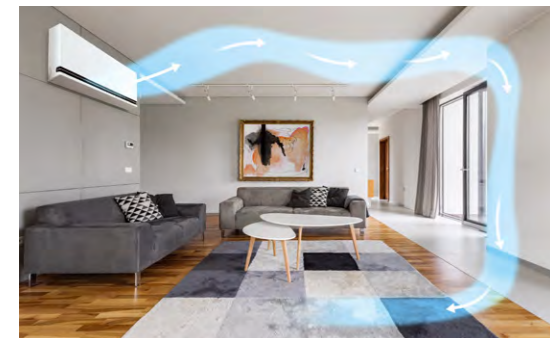

Longer Stream Wind

Two separated vanes are combined to create one large single vane with the longer vane shape, the Dual Vane can send airflow further than conventional models.

Indirect Flow

Dual Vane provide indirect mode for more comfortable experience compared to single vane. It provides that cold wind blows down from above of head, hot wind comes up from underneath of feet, reducing the discomfort of direct wind contact.



Faster Cooling & Heating

Dual Vane can provide optimized airflow that single vane can not achieve. It enables cooling up to 23% faster and heating up to 6% faster than single vane.

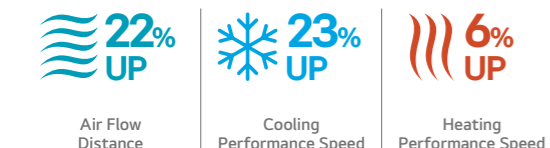

※ Performance comparison vs Single Vane

1) Date 2023.06, Measurement results in LG air conditioner test chamber, installation height 1.8 m, Fan mode. Using a wind speed probe, the height range from 0.1 to 1.7 m is measured in 0.2 m increments. Measures the maximum distance reached by airflow more than 0.25 m/s speed from the products
 2) Date 2023.10 LG air conditioner home environment testing chamber, 20.9 m/50.1 m, Jet Mode, Indoor DB (33±0.3)°C / RH (60±5)%, Outdoor DB (35±0.3)°C / RH (50±5)% 18°C setting on cooling mode, Indoor DB (12±0.3)°C / RH (60±5)%, Outdoor DB (7±0.3)°C / RH (87±5)% 30°C setting on heating mode, measured the time took reduce 5°C (for Cooling) / rise 5°C (for heating), from the initial average room temperature. Test Model : S3-M12KL2MB (SK), S3-M12L1C0 (S1 New Platform)

kW Manager by LG ThinQ

Stay cool. kW Manager lets you take control of your energy usage and spending proactively.

※ When connected to Multi ODU, this function is not supported.

Proactive Energy Saving

Human Detecting Sensor

Proactive Energy Saving

Human Detection Sensor's location detector provides comfy airflow control and auto power-savings.

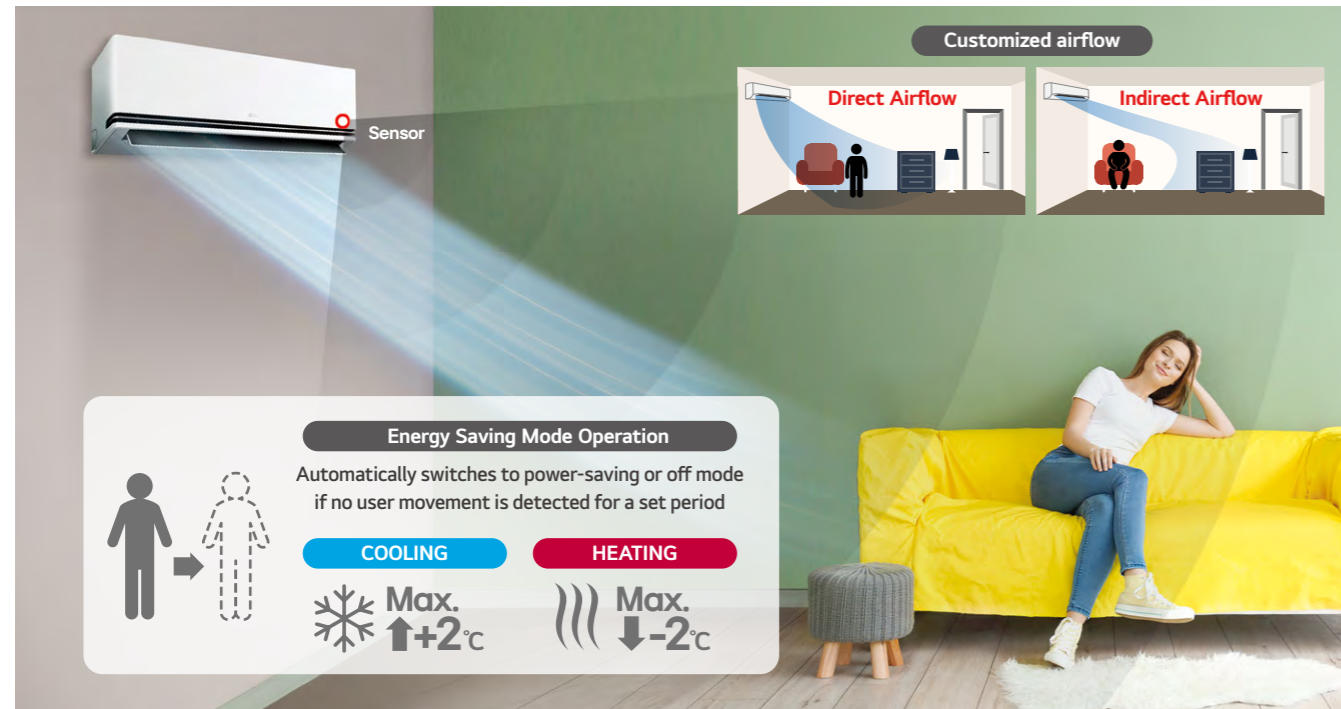

- ※ This function can be turned on/off through remote controller or LG ThinQ app.
- ※ The "Human Detection Sensor" only activates cooling and heating mode.
- ※ The judgment time of absence human detection can be set from 20 to 120 min through LG ThinQ app (Default 20 min).
- ※ Human body detection covers 100 degrees left and right based on the product, and the maximum detection distance is 5 m.
- ※ Depending on usage conditions, sensor detection range may be shortened.

Window Open Detecting

Proactive Energy Saving

Reduces energy loss as energy saving mode starts automatically during sudden temperature changes. Prevents condensation when window open.

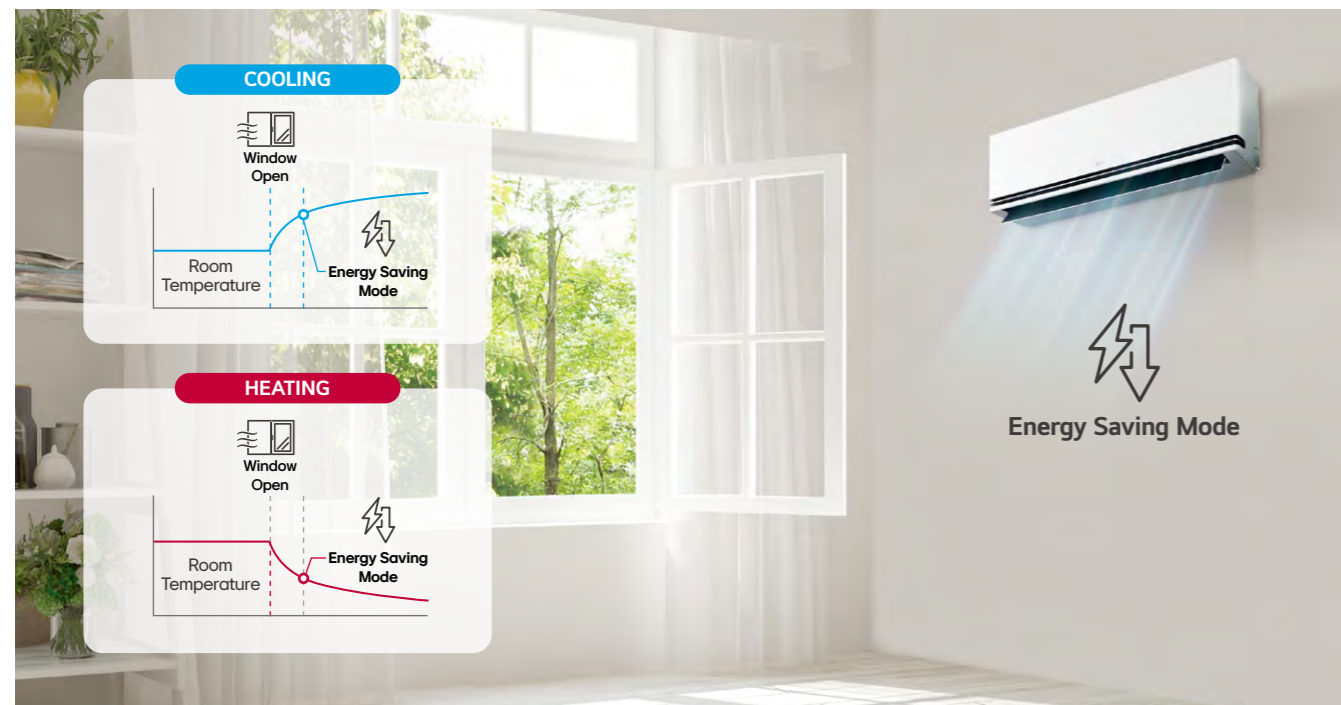

- ※ The initial setting is off when the product is shipped.
- ※ This function can be set up through LG ThinQ app only.
- ※ The "Window open detection" function is available in Cooling and Heating mode only.
- ※ The default energy saving mode operating time is 10 minutes and can be set up to 60 minutes through LG ThinQ app.

Total Air Care

Total Air Care

A multi-step filtration process with Freeze Cleaning that purifies the air, removing dust and even bacteria, ensuring the air you breathe is always fresh.



How It Works

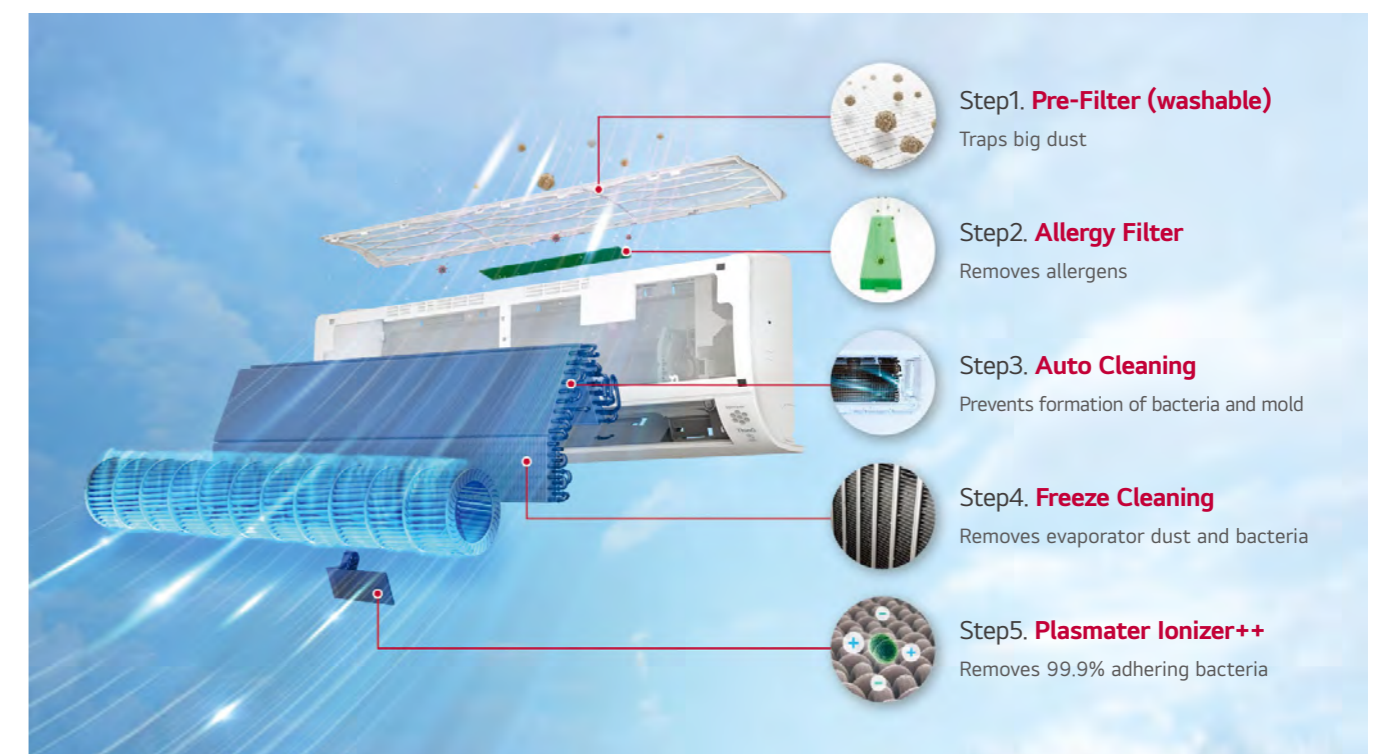

A new air conditioner designed to seamlessly integrate with your senses and interior.

LG ARTCOOL™ Gallery

Premium / Special



Key Feature

Explore the ARTCOOL 2nd Evolution Gallery – an interior masterpiece.

Art Display (27" Full HD LCD)

Experience a 27" Full HD LCD display incorporated into the air conditioning unit. Customize the screen to suit your mood and preferences.



Wood Frame Design

Featuring a modern and luxurious design that seamlessly harmonizes with any space.



The ARTCOOL Gallery has Excellence Design Awards from the IDEA. (International design excellence awards)

Create the interior settings using the LG ThinQ App

Choose up to 20 photos from your phone and send them to Look at Me through the ThinQ app, allowing you to view them on the air conditioner.

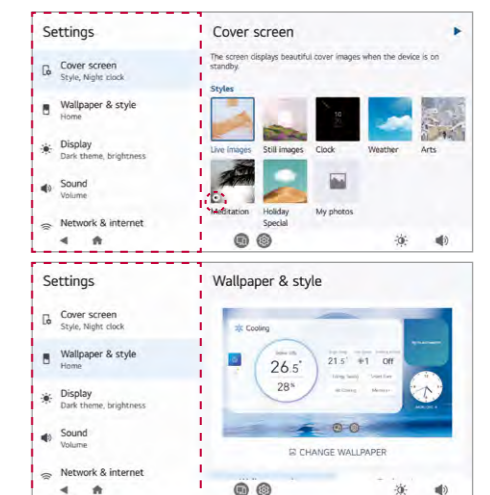
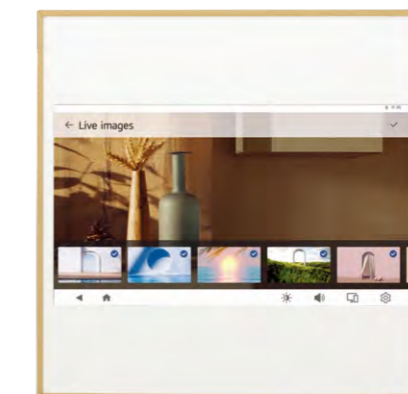

Anytime, Anywhere!

LG DUALCOOL™ powered by ThinQ with Voice Control



Key Feature

Elevate your daily routine with ThinQ

Cool home when you arrive
"Imagine arriving to a perfectly cool home"

Monitor monthly electricity bills
"Track your AC usage and stay informed about your monthly electricity consumption."

Switch off AC after you've left
"No more worries about leaving the AC on – switch it off with a tap."

No need to search for the remote control your AC effortlessly with your phone.
"Where's the remote control? I'm too lazy to go search for it."

Voice control for an enhanced lifestyle

- Intuitive control for convenient, anytime, anywhere access.
- Enjoy increased comfort made accessible and simple for everyone.
- Save time without the burden of searching for the remote control.

Simple voice control for convenience and accessibility

Experience the ease of simple voice control, saving you valuable time otherwise searching for the remote control. DUALCOOL models are also compatible with AI speakers like ThinQ with Google Assistant, Google Home, and more. Say goodbye to pressing buttons – use your voice instead.

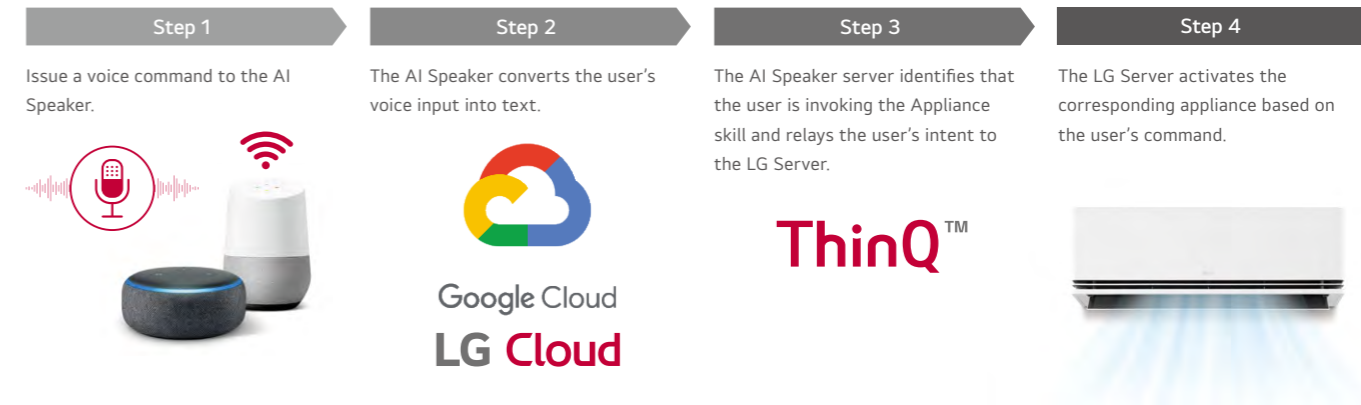













※ Smart features and voice assistant product may vary by country and model. Check with your local retailer or LG for service availability.

WALL MOUNTED



○ Single Split Only ● Compatible ● Multi Split Only

MODEL	kBTu kW	5	7	9	12	15	18	24		
		1.5	2.1	2.6	3.5	4.2	5.3	7.0		
LG ARTCOOL™	Gallery Premium				○● A09GA2.NSE	○● A12GA2.NSE				
	Gallery Special				○● A09GA1.NSE	○● A12GA1.NSE				
	Mirror			● AM07BK.NSJ	○● AC09BK.NSJ	○● AC12BK.NSJ		○● AC18BK.NSK	○● AC24BK.NSK	
LG DUALCOOL™	Prestige				○ F09MT.NSM	○ F12MT.NSM				
	Premium				○● H09S1PNS1	○● H12S1PNS1				
	Deluxe				○● H09S1D.NS1	○● H12S1D.NS1	○● H18S1D.NS1	○● H24S1D.NS1		
	Special DC1			● DM07RK.NSJ	○● DC09RK.NSJ	○● DC12RK.NSJ	○● DC18RK.NSK	○● DC24RK.NSK		
	Special DC2				○● DC09RT.NSJ	○● DC12RT.NSJ				
	Special PC			● PM05SK.NSA	● PM07SK.NSA	○● PC09SK.NSJ	○● PC12SK.NSJ	● PM15SK.NSJ	○● PC18SK.NSK	○● PC24SK.NSK
	Special ET			● MS07ET.NSA	○● S09ET.NSJ	○● S12ET.NSJ	○● S18ET.NSK	○● S24ET.NSK		
	Special EQ				○ S09EQ.NSJ	○ S12EQ.NSJ	○ S18EQ.NSK	○ S24EQ.NSK		
	Pro				○ W09TI.NEU	○ W12TI.NEU	○ W18TI.NEU	○ W24TI.NEU		
					○ W09TE.NEU	○ W12TE.NEU				

※ Refer to multi split line up for 5, 7, 15 kBTu indoor unit connection.

○ Single Split Only ● Compatible ● Multi Split Only

MODEL	kBTu kW	5	7	9	12	15	18	24
		1.5	2.1	2.6	3.5	4.2	5.3	7.0
LG ARTCOOL™	Gallery Premium				○ A09GA2.U18	○ A12GA2.U18		
	Gallery Deluxe				○ A09GA1.U18	○ A12GA1.U18		
	Mirror				○ AC09BK.UA3	○ AC12BK.UA3		○ AC18BK.U18
LG DUALCOOL™	Prestige				○ F09MT.U24	○ F12MT.U24		
	Premium				○ H09S1PU18	○ H12S1PU18		
	Deluxe				○ H09S1D.U12	○ H12S1D.U12	○ H18S1D.U18	○ H24S1D.U24
	Special DC1				○ DC09RK.U12	○ DC12RK.U12	○ DC18RK.U18	○ DC24RK.U24
	Special DC2				○ DC09RT.UA3	○ DC12RT.UA3		
	Special PC				○ PC09SK.UA3	○ PC12SK.UA3	○ PC18SK.U18	○ PC24SK.U24
	Special ET				○ S09ET.UA3	○ S12ET.UA3	○ S18ET.U18	○ S24ET.U24
	Special EQ				○ S09EQ.UA3	○ S12EQ.UA3	○ S18EQ.U18	○ S24EQ.U24
	Pro				○ W09TI.UEU	○ W12TI.UEU	○ W18TI.UEU	○ W24TI.UEU
					○ W09TE.UEU	○ W12TE.UEU		

powered by DUAL Inverter HeatPump Compressor™

※ Dual Inverter HeatPump Compressor is applied to Single Split only. Specification may vary each model.

What is the Dual Inverter HeatPump Compressor?

A compressor is the heart of an air conditioner. LG's Dual Inverter HeatPump Compressor solves conventional compressor problems, resulting in an air conditioner that cools faster, lasts longer, and runs quieter.



Product Reliability Improvement

The Dual Inverter HeatPump Compressor reduces the vibration and with it the sound pressure levels. The reduction in vibration reduces the possibility of fractures occurring in the the surrounding pipework.

How It Works

Varied-Speed Dual Rotary

A compressor motor with a wider rotational frequency that is energy efficient and has a higher volumetric quick cooling capacity than any conventional compressors.

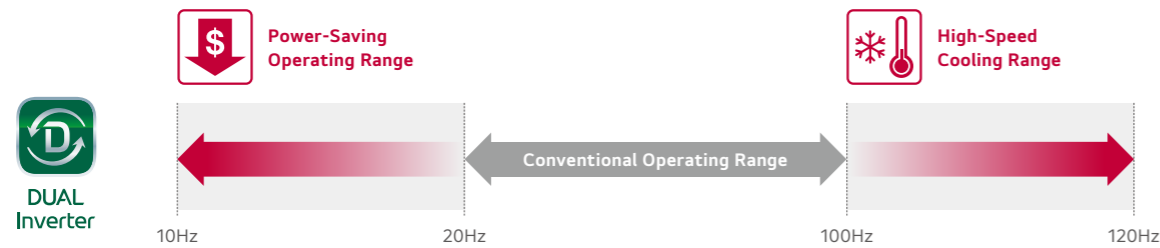

Low Noise

LG air conditioners operate at 19dB low noise level.

※ Specifications may vary for each model.

How It Works

LG's Unique Skew Fan

By minimizing the surface pressure of the fan blade when in contact with the air, the noise produced by the air conditioning unit is reduced to a remarkably low level.



ALVC (Active Low Vibration Control)

A speed-error component estimates the load to compensate for imbalances, which are the primary causes of vibration and noise, enabling the rotation of the motor without vibration at low Hz levels.

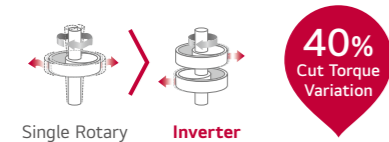

BLDC Fan Motor

With strong torque and powerful ND magnetism as well as precise speed control of 13 different steps for smooth operation, the BLDC motor provides substantial air volume and high static pressure, while keeping electrical and mechanical noise lower, and making high-speed operation available.

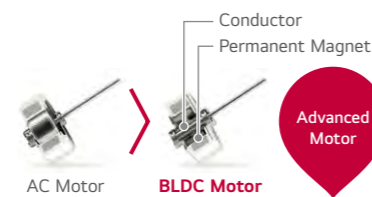

Conventional AC Motor

- Low efficiency.
- Heat problem during overhauling.
- Difficult precise speed control.

BLDC Motor

- Low electric and mechanical noise.
- Durable precise speed control.

Benefit

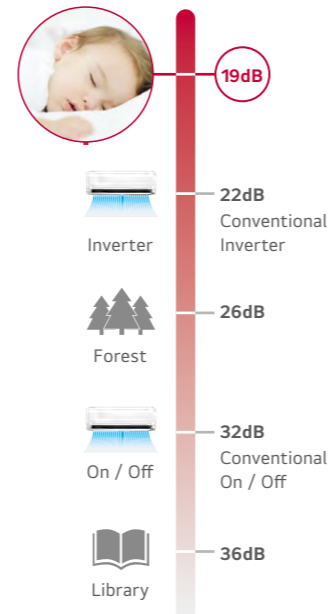

Active Energy Control

LG's Active Energy Control operates in four steps, dynamically adjusting both energy consumption levels and cooling capacity. This is achieved through precise control of the maximum frequency of the compressor motor.

※ Specifications may vary for each model. ※ Depending on the experimental conditions.
※ When connected to Multi ODU, Active Energy Control function may not be supported. ※ Active Energy Control works only cooling mode.

Concept & Benefit

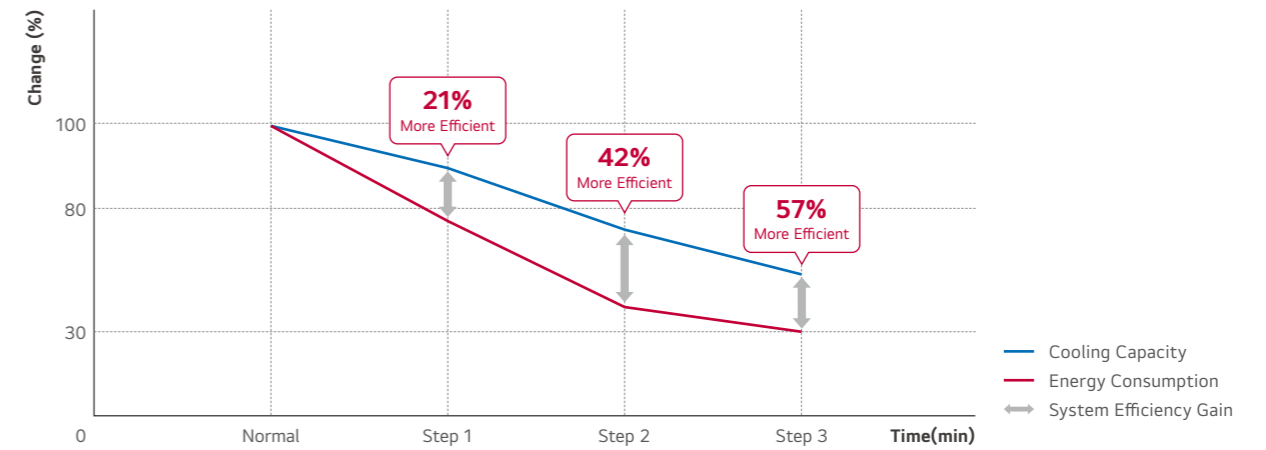

※ Test Conditions : Normal Temperature (Indoor Temperature at the Cooling Mode : 28°C, Outdoor Temperature : 32°C)
※ Test Model : DC12RH

How It Works

STEP 1 100% Energy Usage

Suitable for many people and high-activity levels.

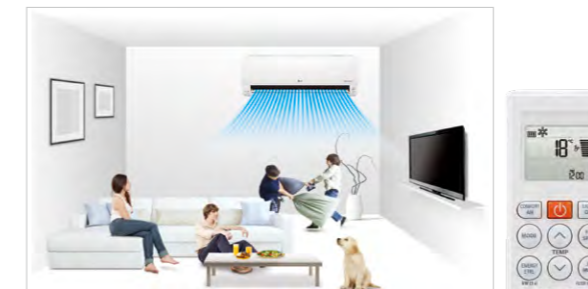

STEP 2 80% Energy Usage

Ideal for fewer people and moderate-activity levels.

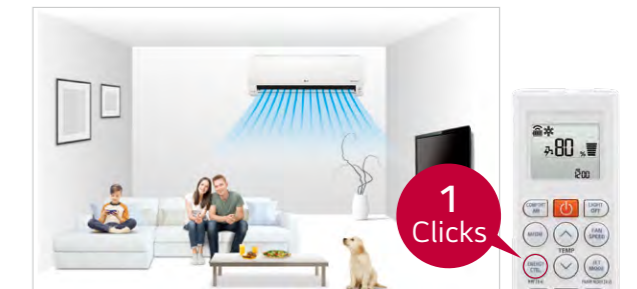

STEP 3 60% Energy Usage

Designed for even fewer people and low-activity levels.



STEP 4 40% Energy Usage

Intended for the fewest people with no activity.



Fast Cooling

The cool airflow rapidly reaches all the corners of the room, keeping the space cool and comfortable.

※ Specifications may vary for each model. ※ Depending on the experimental conditions.

Pain Point

Bigger Skew Fan

Experience a 25% larger skew fan that generates highly powerful air blasts for efficient cooling.

25%
Larger (Fan Size)

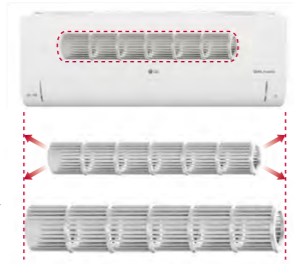

Cooling Outlet

The larger and optimally designed cooling outlet ensures broader coverage, rapidly cooling larger areas for a more comfortable environment.

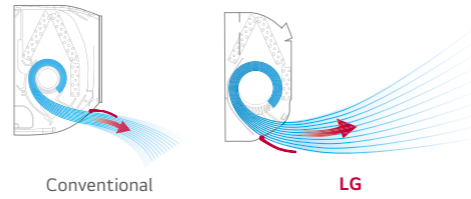

Test Result

Test Result

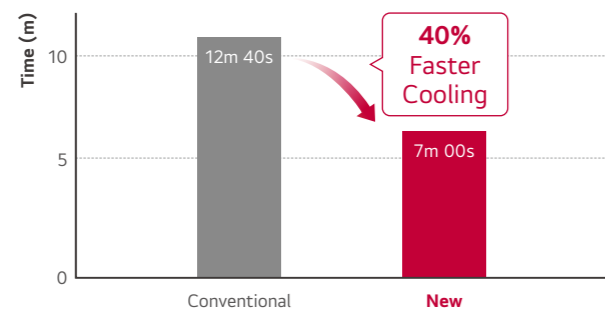

※ 26.5°C Reach Time Comparison
 ※ Test Model
 - Conventional : TS-H2465DA0
 - New : US-Q242Kxy0
 ※ Test Conditions :
 Indoor temperature 33°C, Outdoor temperature 35°C,
 Relative humidity 60%, Setting temperature 26°C
 Test room size : 4.3 m x 7.0 m x 2.3 m

Fast Heating

LG Residential Air Conditioners satisfy user needs by consuming less energy and heating a wider space in a shorter period. This creates a warm and comfortable living environment.

※ Specifications may vary for each model. ※ Depending on the experimental conditions.

How It Works

4 Way Auto Swing (Easy Airflow Control)

The 4-Way Auto Swing feature adjusts airflow dynamically based on the surrounding environment. This ensures the optimal distribution of warm air throughout living areas, facilitating quick and efficient heating.

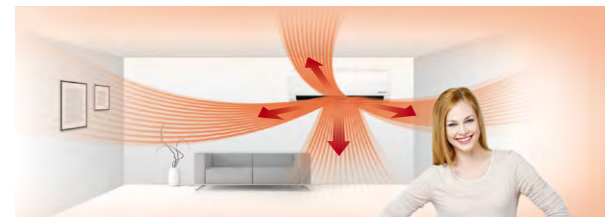

Vertical Airflow

During heating, the vane directs warm air downward, ensuring a pleasant and balanced room temperature.

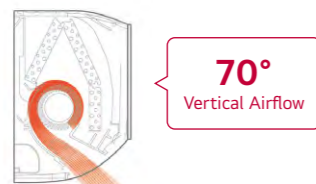

Benefit & Test Result

22% Quick Heating

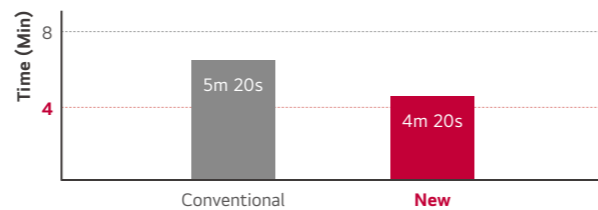

※ Test Conditions :
 Outdoor temperature : 7°C, Indoor temperature : 12°C,
 Humidity : 87%, Remote control : 30°C Power

Changes in Temperature Over 20 Minutes



※ Test Conditions :
 Outdoor temperature : 7°C, Indoor temperature : 12°C,
 Humidity : 87%, Remote control : 30°C Power

Freeze Cleaning

Experience continuous freshness as our innovative Freeze Cleaning technology ensures a clean evaporator, allowing the passage of fresh and pure air.

Pain Point

When using an air conditioner, concerns often arise regarding the cleanliness of the air it produces. The interior of an air conditioner, being a dark and humid environment, is prone to contamination by dust and bacteria.

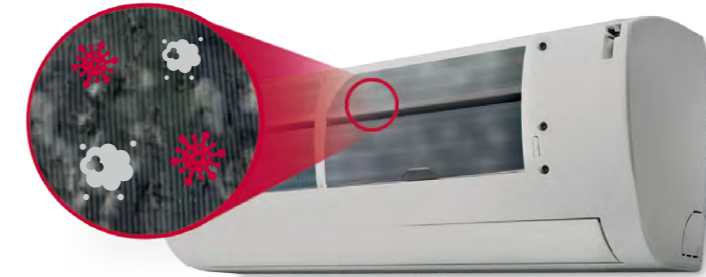

How It Works

The "Freeze Cleaning" process involves creating an ice layer that effectively separates odor-causing substances, including dust and bacteria accumulated on the evaporator. When the ice melts, these contaminants are efficiently washed away with the drain water, ensuring a thorough cleaning mechanism.

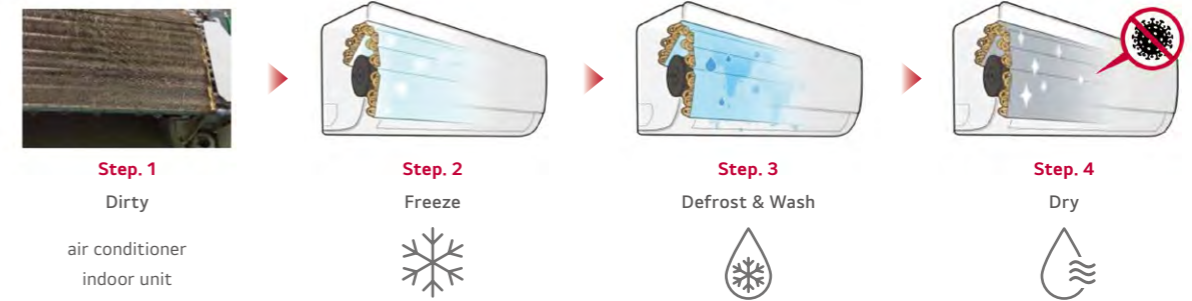

※ Working condition : 21 ~ 32°C (Indoor) / 21 ~ 37°C (Outdoor)
 ※ The "Freeze Cleaning" mode can activate through ThinQ only.

Benefit & Verification

Periodically clean the interior of the air conditioner, a typically challenging maintenance task, to keep the evaporator consistently clean.

Test Result (Bacterial Removal Performance)

Our "Freeze Cleaning" function has been rigorously tested and proven to remove up to 99.0% of residual bacteria on the evaporator, ensuring a hygienic and healthy environment.

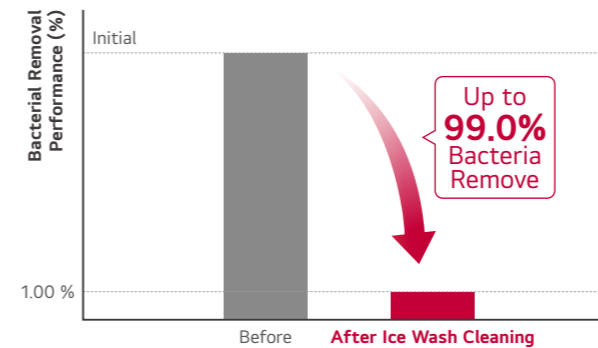

※ This test result obtained a test report on and Pseudomonas aeruginosa 99.0% reduction rate from an internationally recognized laboratory, which may vary depending on the actual environment.
 ※ Test institution : TÜV Rheinland
 ※ Test Model : SQ07EDETHN(SE), SQ06BDAWAJ(SA), SQ07SDJBAN(SJ), SQ09MDKWAN(SK)
 ※ Test bacteria : Up to 99% reduction rate of "Pseudomonas aeruginosa" confirmed

Plasmaster™ Ionizer⁺⁺

The powerful Plasmaster™ Ionizer⁺⁺ removes unpleasant odors, along with Escherichia coli and Staphylococcus on surfaces, using over 8 million ions. Experience a safer, cleaner indoor environment.

- ※ Specifications may vary for each model.
- ※ Depending on the experimental conditions.

How It Works

Reduction and Deodorization (Utilizes Over 8 Million Ions)

Plasmaster Ionizer⁺ reduces E.coli and Staphylococcus in the surface with over 8 million ions.

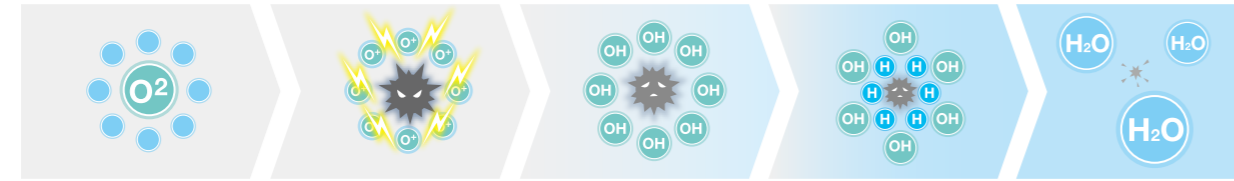

Release of Ions into Air	Surrounding Harmful Substances	OH Radical Production	Chemical Reaction	Disinfection
Ions are released into the air.	H- and O- bond to harmful particles.	OH radicals inactivate harmful substances.	OH radicals bond with H particles.	H ₂ O molecules are produced.

Test Result

Effective Reduction Performance

Remove Bacteria E.coli over 99.9% in 20 min

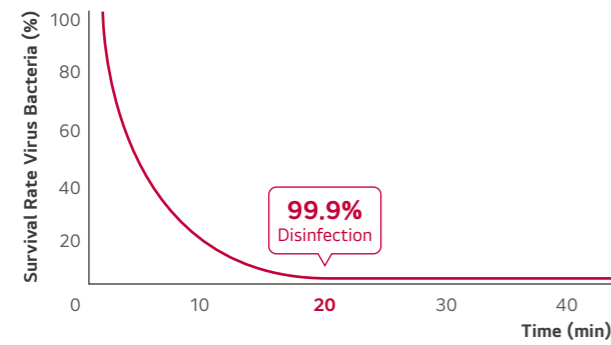

- ※ Test Conditions :
Space : 30m³ Chamber (Measuring with the specimen in the center of test chamber)
Temperature & Humidity : Normal
Bacteria : E Coli colon bacillus
Verified by Intertek & TÜV Rheinland

Staphylococcus Sterilization

Remove Staphylococcus aureus over 99.9% in 60 min

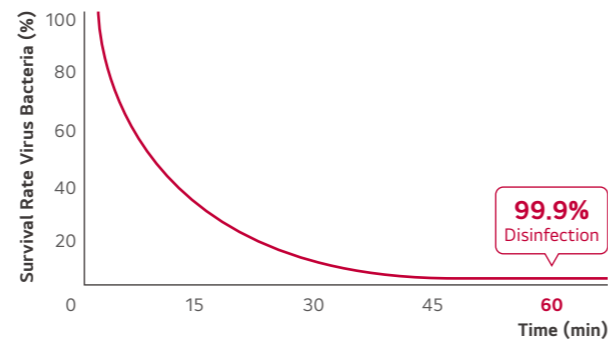

- ※ Test Conditions :
Space : 30m³ Chamber (Measuring with the specimen in the center of test chamber)
Temperature & Humidity : Normal
Bacteria : Staphylococcus Aureus
Verified by Intertek & TÜV Rheinland

Benefit & Verification

The LGE's ionizer, known as "Plasmaster Ionizer Plus," has demonstrated the capability to remove more than 99.9% of bacteria, including Escherichia coli, Pseudomonas aeruginosa, and Staphylococcus aureus.

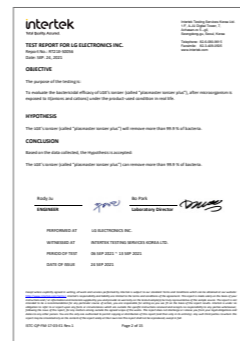

Allergy Filter

While airflow from an air conditioner may trigger symptoms associated with allergies or asthma, LG units feature an interior filter designed to absorb harmful particles such as dust mites, pollen, fungi, and mold that circulate in the air. This ensures a cleaner and more allergen-free environment.

- ※ Specifications may vary for each model.

How It Works

Removes allergy-causing substances, such as dust mites that can be found in the air.

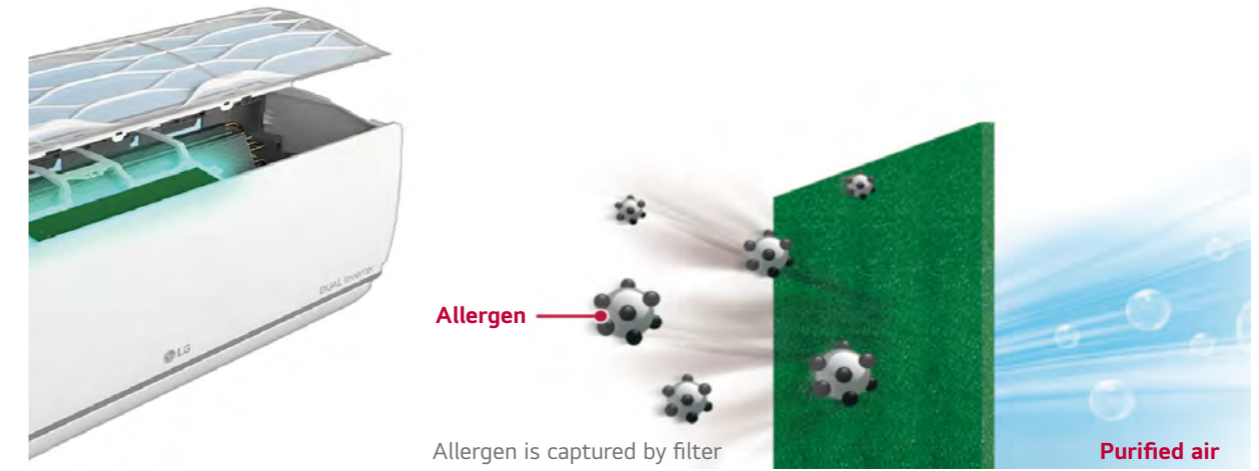

Certification



Certified by AllergyUK

- * Test Condition Disclaimer
A filter is coated to absorb harmful substances that can cause allergies. The air conditioner strongly absorbs indoor air and removes allergy-causing substances, such as house dust mite, fungi, mold, floating in the air.

Allergy UK (a world-renowned organization) is a British medical charity dedicated to helping adults and children with their allergies. The charity was founded in 1991 as the British Allergy Foundation, and in 2002 the operational name of the charity became Allergy UK. Allergy UK endorses certain products that restrict or remove high levels of allergens and gives them a Seal of Approval.

UVnano™

LG DUALCOOL, keeping the fan (inside the unit) 99.99% bacteria-free with ultraviolet light to ensure that the air passing through is clean too.

※ UVnano is an integrated marketing name that applies LG Electronics' entire home appliances and it is a compound of the words UV (ultraviolet) and nanometer (unit of length).

What Is UVnano™ and How It Works?

- Emit Ultraviolet rays of UVC wavelength directly damage the DNA of microorganisms (bacteria/mold/viruses) making it impossible for them to multiply.
- High absorption into DNA at 260 to 270 nm wavelengths

DNA Absorption Efficiency by Wavelength

Electromagnetic Spectrum and Types

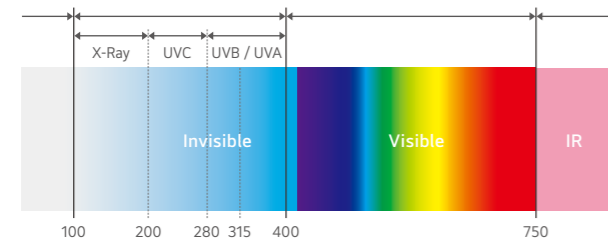

Destruction Nuclear Sequence (Chain)

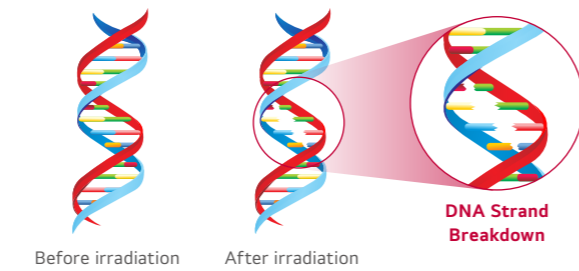

UVC Applied Product

LG Product



Various Product Lines

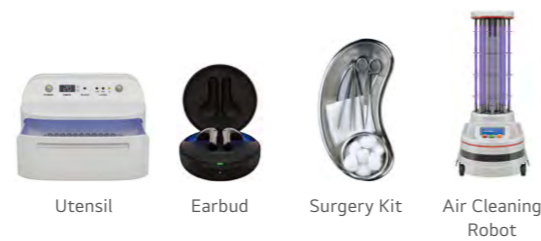

Benefit & Verification

Keep the fan 99.99% bacteria-clean for a cleaner breeze.



Removes up to **99.99%** of bacteria from the internal fan.



※ Test Condition
 - Test Model : S3NM12JL1GA(SJ), S3NM24K21GA(SK)
 - Test Standard : LG test method with referenced to ISO 20743:2007
 - Bacteria : Staphylococcus aureus, Staphylococcus epidermidis, Klebsiella pneumoniae

Auto Cleaning

The interior of the air conditioner is maintained clean by drying off the heat exchanger, then cleaning the interior once more.

※ Specifications may vary for each model.

Pain Point

The main cause of odor within air conditioners is mold and bacteria growing on the heat exchanger. These germs can spread when the heat exchanger is wet.

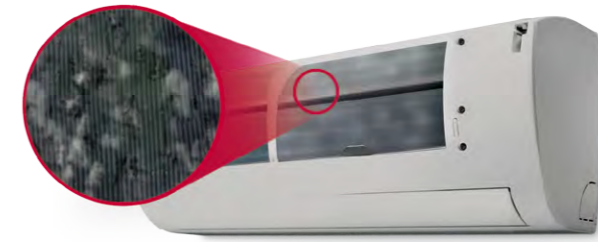

How It Works

Cleans Filter with Regular Air Flow

The comprehensive auto cleaning function prevents the formation of bacteria and mold on the heat exchanger, providing an enhanced environment.

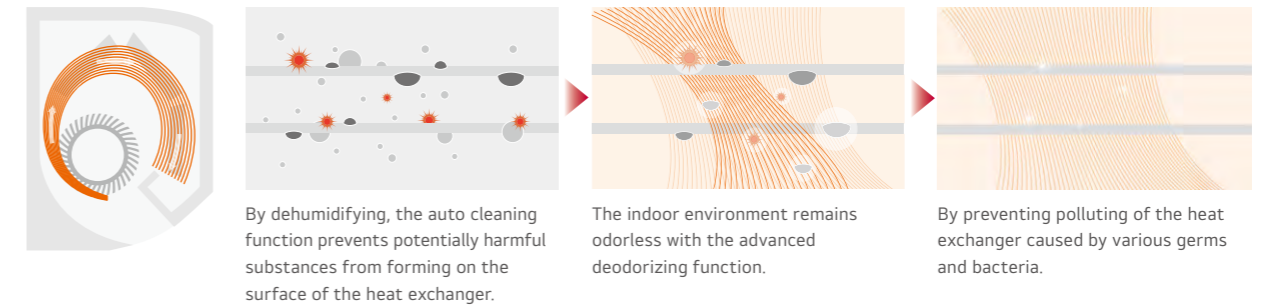

Benefit

Removes Harmful Particles

Auto Cleaning provides clean air by preventing bacteria, mold and odors that can otherwise accumulate in an indoor unit.

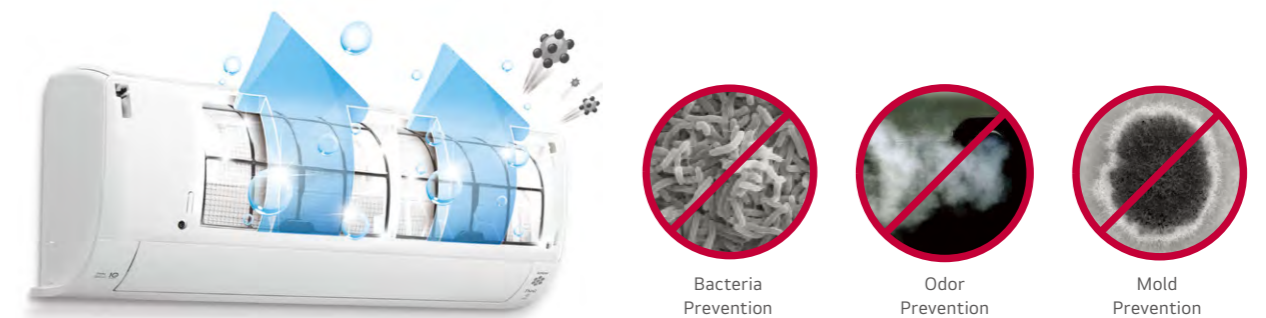
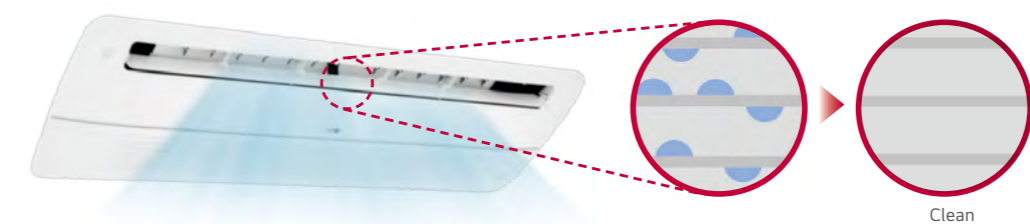

Low Refrigerant Detection

Receive early notifications of low refrigerant levels to safeguard your air conditioner from potential damage.

- ※ Specifications may vary for each model. ※ Depending on the experimental conditions.
- ※ When connected to Multi ODU, the Low Refrigerant Detection function may not be supported.

How It Works

Early Detection of Low Refrigerant Levels

The Air Conditioner features an automatic shutdown mechanism upon detecting low refrigerant levels, ensuring proactive protection.

3 Checkpoints for Low Refrigerant Level

- 1) The heat exchanger temperature is relatively cool.
- 2) The outdoor unit is functioning correctly.
- 3) Energy consumption adheres to a standard pattern.

If any of the above conditions are not met, for a maximum of four instances, after 15 minutes of Air Conditioner operation, a low refrigerant level is detected, triggering an automatic shutdown for enhanced system safety.

Capacity and Effectiveness of the Refrigerant Levels

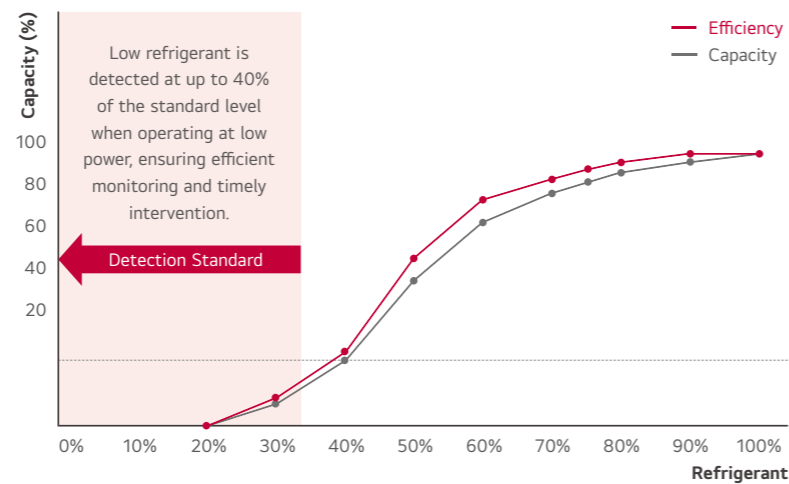

- ※ This function only works under the following conditions
- Indoor/Outdoor temperature is at least 20°C
- Cooling and dehumidification mode

Benefit

Longer Lifespan for Air Conditioner



※ Some models show CH and 38 alternately on the display.

Embedded Wi-Fi

Effortlessly manage your air conditioners using Android or iOS smartphones with the embedded Wi-Fi feature.

- ※ Specifications may vary for each model.

ThinQ

Download the ThinQ app from Google or Apple app stores.



How It Works

① Turn on "ThinQ" on your air conditioner

Benefit from the embedded Wi-Fi modem and enjoy unlimited innovation.



② Enjoy Unlimited Innovation

Once registered, experience seamless connectivity and explore the innovative features offered through ThinQ.

Wi-Fi Connectivity

Experience individualized comfort with Wi-Fi connectivity. Each family member can customize the air conditioner temperature and fan speed using their app, saving preferences for future use. These personalized settings can be stored for each specific air conditioner.

Multiple Devices



Multi-Control



※ Can be controlled by multiple users, but not simultaneously.

③ Easy Registration and Log-in

Follow the interactive setup steps to activate ThinQ's impressive features by setting up your LG Account.

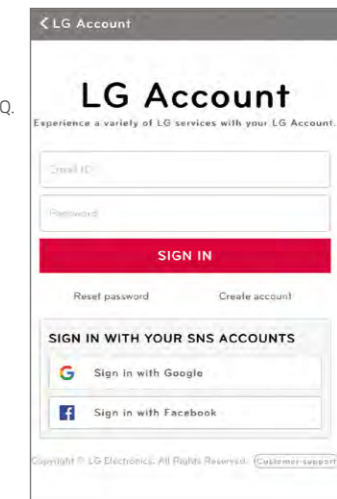

Benefit

Simple operation for various functions

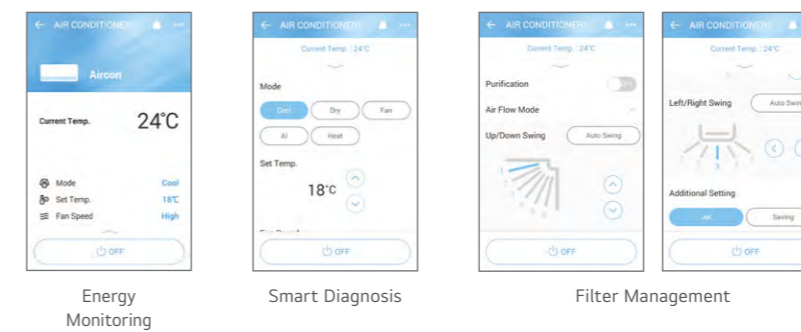

Straight-forward management

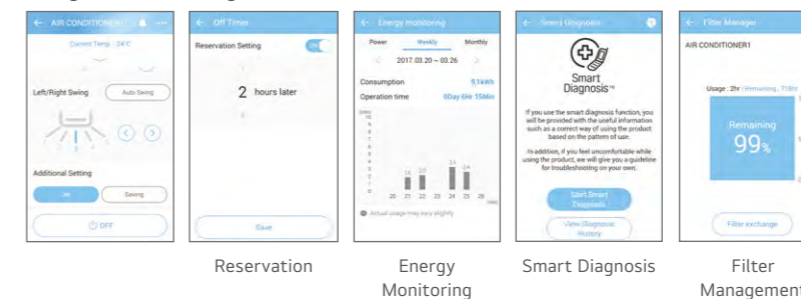

※ For our policy of continuous ThinQ App improvement, specification, design and features are subject to change without prior notice.

Integrated Home Appliances Control

Monitor and control your LG appliances from one place.



Access your air conditioner anytime and from anywhere with a Wi-Fi equipped device and LG's exclusive control app, ThinQ.



Smart Diagnosis

Smart Diagnosis allows you to monitor the health of your air conditioner remotely.

- ※ Specifications may vary for each model.
- ※ When connected to Multi ODU, Smart Diagnosis function may not be supported.

What is Smart Diagnosis?

Smart Diagnosis allows users to conveniently check setup, installation, troubleshooting and other information directly from a smartphone.

- ※ Builds upon widespread smartphone use and offers greater USP diversification
- ※ Perfect for consumers who are unable to view information about their air conditioner via a display or remote control.

How It Works

Embedded Wi-Fi Model

By using "ThinQ" App and clicking "Start Smart Diagnosis", monitor and check diagnosis results conveniently via Wi-Fi.

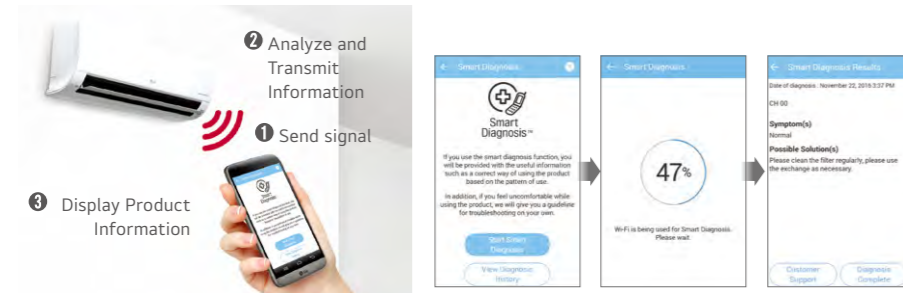

Non Embedded Wi-Fi Model

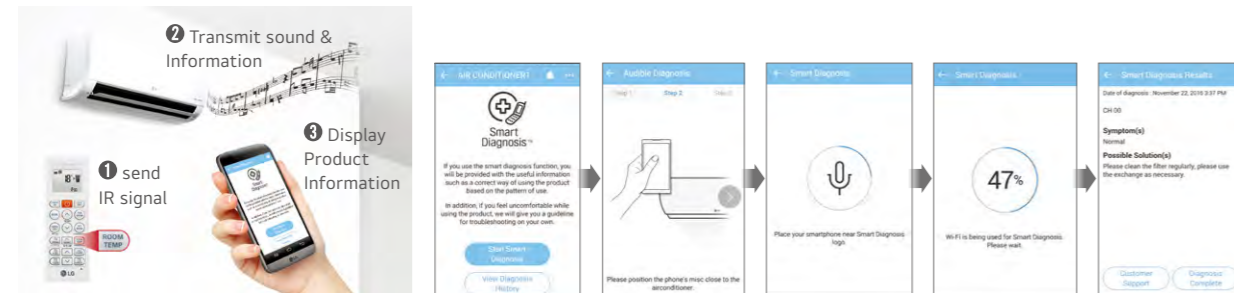

Benefit

Easily understandable error messages simplify the process of identifying solutions and make reaching out to the service center simple and convenient.

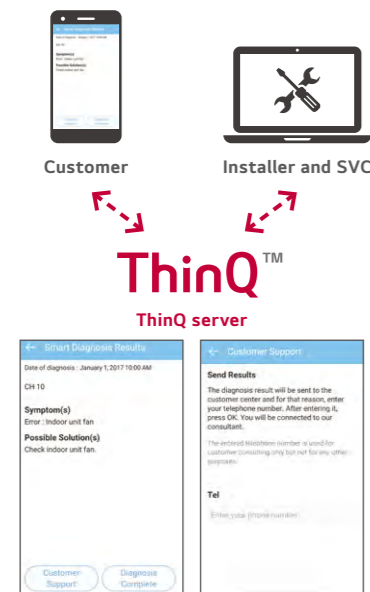

For Consumer



- Easily check the operational status of a product, even without a display or with limited information.
- Save energy by monitoring key operational information and power consumption.
- Utilize the Maintenance Guide to enhance device performance and increase the product's lifespan.

For Installer and SVC

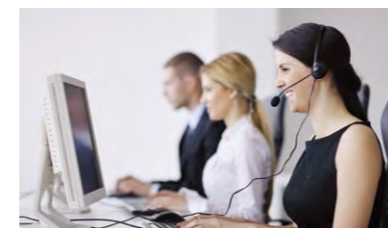

- Gain a better understanding of the product by easily confirming operational status and information.
- Intuitively diagnose problems by comparing current and past usage data.
- Maintain installation capabilities and reduce errors by quickly confirming device operational status.

※ For our policy of continuous ThinQ App improvement, specification, design and features are subject to change without prior notice.

Mobile LGMV (Monitoring View)

LG MV simplifies the inspection (diagnosis) and monitoring of air conditioning units for engineers, allowing easy access through your smartphone or PC.

- ※ Specifications may vary for each model.

PC Version

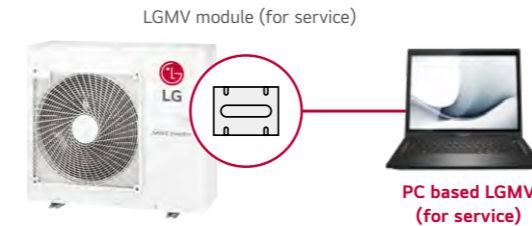

Operation Information

Cycle View

Smartphone Version

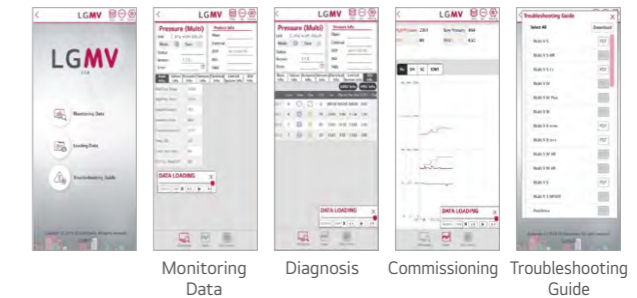

Monitoring Data

Diagnosis

Commissioning

Troubleshooting Guide

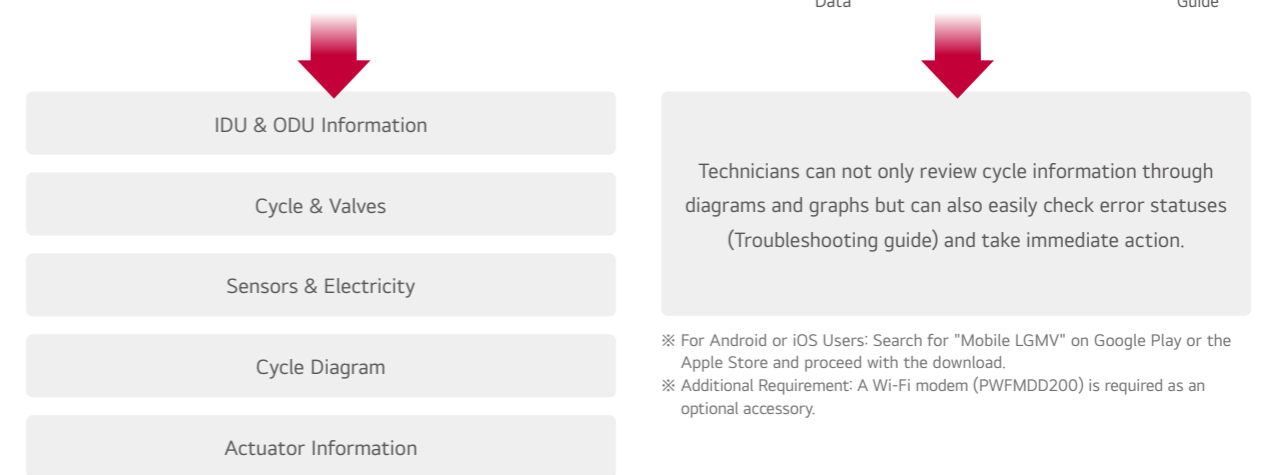

Technicians can not only review cycle information through diagrams and graphs but can also easily check error statuses (Troubleshooting guide) and take immediate action.

- ※ For Android or iOS Users: Search for "Mobile LGMV" on Google Play or the Apple Store and proceed with the download.
- ※ Additional Requirement: A Wi-Fi modem (PWFMD200) is required as an optional accessory.

Gold Fin™

The Gold Fin™ coating protects the surface of the heat exchanger from unnecessary wear and corrosion.

※ Specifications may vary for each model. ※ Depending on the experimental conditions.

How It Works

Corrosion-resistant protective layer

The gold-colored special coating on the fin of the heat exchanger prevents corrosion, extending the life of the unit.

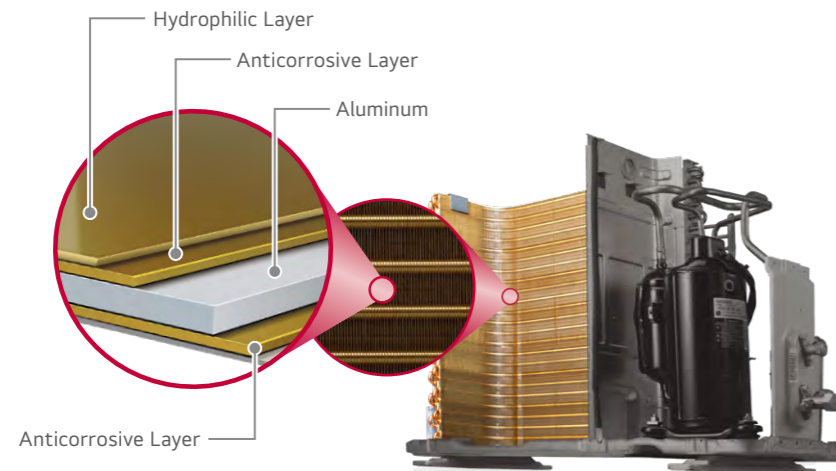

Test Result

Conventional Fin



Gold Fin™



※ Test Condition

- Test standard : ISO9227:2017, ISO10289:1999, ASTM B 117 Salt spray test
- Test Sample : Al Fin sheet (100µm, 70 X 150 mm) + Organic Coating (1.65g/m²)
- Setting Condition : (35±2)°C, 6.5 ~ 7.2 pH, (5±1)% NaCl salt fog spray, 5000 h
- Test Result : Not More than 0.05% of corrosion area ratio. (over R.N. 9.5)



TUV Verify that the corrosion improved "Gold II Fin" has less than 0.05% corrosion area after 5000 hours salt spray test. TUV has verified that the corrosion area of Gold Fin™ is not more than 0.05% (over R.N. 9.5)



LG participates in the ECP programme for EUROVENT AC program. Check ongoing validity of certification : www.eurovent-certification.com

Single Combination

UNIT				9K	12K
INDOOR				A09GA2.NSE	A12GA2.NSE
Capacity	Cooling	Min. / Rated / Max.	kW	0.89 / 2.50 / 3.70	0.89 / 3.50 / 4.04
	Heating	Min. / Rated / Max.	kW	0.89 / 3.30 / 4.10	0.89 / 4.00 / 4.70
Power Input	Cooling / Heating	Rated	W	600 / 808	1,020 / 1,078
			W/W	4.17	3.43
EER				7.2	6.9
S.E.E.R.				2.5	3.5
COP			W/W	4.08	3.71
S.C.O.P		(Average / Warmer)		4.3 / 4.9	4.3 / 4.9
P design H (Average / Warmer)			kW	2.7 / 1.4	2.7 / 1.4
Energy Label (A+++ to D Scale)	Cooling			A++	A++
	Heating	(Average / Warmer)		A+ / A++	A+ / A++
Annual Energy Consumption	Cooling		kWh	121	177
	Heating	(Average / Warmer)	kWh	879 / 373	879 / 373
Sound Pressure*	Cooling	S / L / M / H	dB(A)	20 / 28 / 36 / 42	20 / 28 / 36 / 42
	Heating	L / M / H	dB(A)	28 / 36 / 42	28 / 36 / 42
Sound Power	Cooling		dB(A)	60	60
	Heating				
Air Flow Rate	Cooling	S / L / M / H / Max. (Power)	m ³ /min	3 / 6 / 8 / 10 / 12	3 / 6 / 8 / 10 / 12
	Heating	L / M / H	m ³ /min	6 / 8 / 10	6 / 8 / 10
Dehumidification Rate			l/h	1.1	1.3
Running Current	Cooling	Min. / Rated / Max.	A	1.1 / 3.0 / 6.0	1.1 / 4.6 / 6.2
	Heating	Min. / Rated / Max.	A	1.1 / 3.7 / 7.2	1.1 / 4.8 / 7.2
Starting Current	Cooling / Heating	Rated	A	3.0 / 3.7	4.6 / 4.8
Power Supply			Ø / V / Hz	1 / 220-240 / 50	1 / 220-240 / 50
Circuit Breaker			A	20	20
Power Supply Cable			N x mm ²	3 x 1.0	3 x 1.0
Power & Transmission Cable			N x mm ²	4 x 1.0 (Including Earth)	4 x 1.0 (Including Earth)
Dimension			mm	652 x 652 x 158	652 x 652 x 158
Net Weight			kg	20	20
Fan Motor Output			W	32.7	32.7
OUTDOOR				A09GA2.U18	A12GA2.U18
Operation Range	Cooling	Min. / Max.	°C DB	-15 / 48	-15 / 48
	Heating	Min. / Max.	°C DB	-15 / 24	-15 / 24
Sound Pressure*	Cooling / Heating	High	dB(A)	50 / 53	50 / 53
Sound Power	Cooling	High	dB(A)	65	65
Air Flow Rate		High	m ³ /min	35	35
Piping	Liquid (ODU / IDU)	Min. / Max.	m	3 / 20	3 / 20
	Elevation (ODU / IDU)	Min. / Max.	m	10	10
Piping Connection	Liquid	OD (Outside)	mm (inch)	6.35 (1/4)	6.35 (1/4)
	Gas	OD (Outside)	mm (inch)	9.52 (3/8)	9.52 (3/8)
Drain Hose Size		OD (Outside)	mm (inch)	21.5 (27/32)	21.5 (27/32)
Refrigerant	Type			R32	R32
	Charge at 7.5m		kg	0.800	0.800
	t-CO ₂ eq			0.540	0.540
	Additional Charge		g/m	20	20
GWP				675	675
Fan Motor Output			W	43	43
Compressor Type				Twin Rotary	Twin Rotary
Net Weight			kg	33.4	33.4
Dimension			mm	770 x 545 x 288	770 x 545 x 288
ACCESSORIES & OTHERS					
Multi Compatible				Y	Y
PI 485				Y	Y
Dry Contact				Y	Y
Wired Remote Controller				Y	Y

■ Preliminary Data Only

* : Sound Pressure is not a value declared on Eurovent Program.

※ This product contains Fluorinated greenhouse gases (R32).

※ S : Sleep / L : Low / M : Medium / H : High

※ GWP : Global warming potential

※ t-CO₂eq : F-gas(kg)*GWP/1000

※ For our policy of continuous product improvement, specification, design and feature are subject to change without prior notice.

※ Y : Available or Applied / - : Not Available or Not Applied



LG participates in the ECP programme for EUROVENT AC program. Check ongoing validity of certification : www.eurovent-certification.com

Single Combination

UNIT				9K	12K
INDOOR				A09GA1.NSE	A12GA1.NSE
Capacity	Cooling	Min. / Rated / Max.	kW	0.89 / 2.50 / 3.70	0.89 / 3.50 / 4.04
	Heating	Min. / Rated / Max.	kW	0.89 / 3.30 / 4.10	0.89 / 4.00 / 4.70
Power Input	Heating -7°C	Rated	kW	2.60	3.20
	Cooling / Heating	Rated	W	600 / 808	1,020 / 1,078
EER			W/W	4.17	3.43
S.E.E.R.				7.2	6.9
P design C			kW	2.5	3.5
COP			W/W	4.08	3.71
S.C.O.P		(Average / Warmer)		4.3 / 4.9	4.3 / 4.9
P design H (Average / Warmer)			kW	2.7 / 1.4	2.7 / 1.4
Energy Label (A+++ to D Scale)	Cooling			A++	A++
	Heating	(Average / Warmer)		A+ / A++	A+ / A++
Annual Energy Consumption	Cooling		kWh	121	177
	Heating	(Average / Warmer)	kWh	879 / 373	879 / 373
Sound Pressure*	Cooling	S / L / M / H	dB(A)	20 / 28 / 36 / 42	20 / 28 / 36 / 42
	Heating	L / M / H	dB(A)	28 / 36 / 42	28 / 36 / 42
Sound Power	Cooling		dB(A)	60	60
	Heating	S / L / M / H / Max. (Power)	m ² /min	3 / 6 / 8 / 10 / 12	3 / 6 / 8 / 10 / 12
Air Flow Rate	Cooling	L / M / H	m ³ /min	6 / 8 / 10	6 / 8 / 10
	Heating		l/h	1.1	1.3
Running Current	Cooling	Min. / Rated / Max.	A	1.1 / 3.0 / 6.0	1.1 / 4.6 / 6.2
	Heating	Min. / Rated / Max.	A	1.1 / 3.7 / 7.2	1.1 / 4.8 / 7.2
Starting Current	Cooling / Heating	Rated	A	3.0 / 3.7	4.6 / 4.8
Power Supply		Ø / V / Hz		1 / 220-240 / 50	1 / 220-240 / 50
Circuit Breaker			A	20	20
Power Supply Cable			N x mm ²	3 x 1.0	3 x 1.0
Power & Transmission Cable			N x mm ²	4 x 1.0 (Including Earth)	4 x 1.0 (Including Earth)
Dimension			mm	652 x 652 x 158	652 x 652 x 158
Net Weight			kg	20	20
Fan Motor Output			W	32.7	32.7
OUTDOOR				A09GA1.U18	A12GA1.U18
Operation Range	Cooling	Min. / Max.	°C DB	-15 / 48	-15 / 48
	Heating	Min. / Max.	°C DB	-15 / 24	-15 / 24
Sound Pressure*	Cooling / Heating	High	dB(A)	50 / 53	50 / 53
	Cooling	High	dB(A)	65	65
Air Flow Rate	Cooling	High	m ³ /min	35	35
	Liquid (ODU / IDU)	Min. / Max.	m	3 / 20	3 / 20
Piping	Elevation (ODU / IDU)	Min. / Max.	m	10	10
	Liquid	OD (Outside)	mm (inch)	6.35 (1/4)	6.35 (1/4)
Piping Connection	Gas	OD (Outside)	mm (inch)	9.52 (3/8)	9.52 (3/8)
	Drain Hose Size	OD (Outside)	mm (inch)	21.5 (27/32)	21.5 (27/32)
Refrigerant	Type			R32	R32
	Charge at 7.5m		kg	0.800	0.800
	Additional Charge		t-CO ₂ eq	0.540	0.540
	GWP		g/m	20	20
Fan Motor Output			W	675	675
Compressor Type				43	43
Net Weight			kg	33.4	33.4
Dimension			mm	770 x 545 x 288	770 x 545 x 288
ACCESSORIES & OTHERS					
Multi Compatible				Y	Y
PI 485				Y	Y
Dry Contact				Y	Y
Wired Remote Controller				Y	Y

Preliminary Data Only

* : Sound Pressure is not a value declared on Eurovent Program.
 ※ This product contains Fluorinated greenhouse gases (R32).
 ※ S : Sleep / L : Low / M : Medium / H : High
 ※ GWP : Global warming potential
 ※ t-CO₂eq : F-gas(kg)*GWP/1000
 ※ For our policy of continuous product improvement, specification, design and feature are subject to change without prior notice.
 ※ Y : Available or Applied / - : Not Available or Not Applied

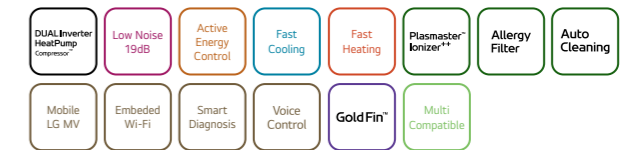

LG participates in the ECP programme for EUROVENT AC program. Check ongoing validity of certification : www.eurovent-certification.com

Single Combination

UNIT				9K	12K	18K	24K
INDOOR				AC09BK NSJ	AC12BK NSJ	AC18BK NSK	AC24BK NSK
Capacity	Cooling	Min. / Rated / Max.	kW	0.89 / 2.50 / 3.70	0.89 / 3.50 / 4.04	0.90 / 5.00 / 5.50	0.90 / 6.60 / 7.42
	Heating	Min. / Rated / Max.	kW	0.89 / 3.30 / 4.10	0.89 / 4.00 / 5.10	0.90 / 5.80 / 6.40	0.90 / 7.50 / 8.64
Power Input	Heating -7°C	Rated	kW	2.60	3.00	4.20	6.00
	Cooling / Heating	Rated	W	656 / 800	1,080 / 1,050	1,562 / 1,611	2,164 / 2,238
EER			W/W	3.81	3.24	3.20	3.05
S.E.E.R.				7.00	6.60	7.00	6.90
P design C			kW	2.50	3.50	5.00	6.60
COP			W/W	4.13	3.81	3.60	3.35
S.C.O.P		(Average / Warmer)		4.00 / 4.90	4.00 / 4.90	4.30 / 5.30	4.30 / 5.30
P design H (Average / Warmer)			kW	2.50 / 1.30	2.50 / 1.30	3.90 / 2.10	5.00 / 2.70
Energy Label (A+++ to D Scale)	Cooling			A++	A++	A++	A++
	Heating	(Average / Warmer)		A+ / A++	A+ / A++	A+ / A+++	A+ / A+++
Annual Energy Consumption	Cooling		kWh	125	186	250	335
	Heating	(Average / Warmer)	kWh	875 / 371	875 / 371	1,270 / 555	1,628 / 713
Sound Pressure*	Cooling	S / L / M / H	dB(A)	19 / 27 / 35 / 41	19 / 27 / 35 / 41	31 / 34 / 39 / 44	31 / 34 / 42 / 47
	Heating	L / M / H	dB(A)	27 / 35 / 41	27 / 35 / 41	34 / 39 / 44	34 / 42 / 47
Sound Power	Cooling		dB(A)	59	59	60	65
	Heating	S / L / M / H / Max. (Power)	m ² /min	3.0 / 4.2 / 7.5 / 10.0 / 12.5	3.0 / 4.2 / 7.5 / 10.0 / 12.5	8.0 / 10.5 / 13.0 / 14.5 / 15.5	8.0 / 10.5 / 13.1 / 14.5 / 15.5
Air Flow Rate	Cooling	L / M / H	m ³ /min	5.6 / 7.2 / 10.0	5.6 / 7.2 / 10.0	11.0 / 13.5 / 16.0	11.0 / 14.3 / 17.6
	Heating		l/h	1.1	1.3	1.8	2.5
Running Current	Cooling	Min. / Rated / Max.	A	1.10 / 3.30 / 6.00	1.10 / 4.70 / 6.00	1.20 / 6.90 / 9.00	1.20 / 9.80 / 14.00
	Heating	Min. / Rated / Max.	A	1.10 / 4.00 / 7.00	1.10 / 4.70 / 7.00	1.20 / 7.10 / 9.50	1.20 / 10.00 / 14.00
Starting Current	Cooling / Heating	Rated	A	3.30 / 4.00	4.70 / 4.70	6.90 / 7.10	9.80 / 10.00
Power Supply		Ø / V / Hz		1 / 220-240 / 50	1 / 220-240 / 50	1 / 220-240 / 50	1 / 220-240 / 50
Circuit Breaker			A	15	15	20	25
Power Supply Cable			N x mm ²	3 x 1.0	3 x 1.0	3 x 1.5	3 x 2.5
Power & Transmission Cable			N x mm ²	4 x 1.0 (Including Earth)	4 x 1.0 (Including Earth)	4 x 1.0 (Including Earth)	4 x 1.0 (Including Earth)
Dimension			mm	837 x 308 x 192	837 x 308 x 192	998 x 345 x 212	998 x 345 x 212
Net Weight			kg	9.9	9.9	12.8	13.5
Fan Motor Output			W	30	30	30	58
OUTDOOR				AC09BK UA3	AC12BK UA3	AC18BK UL2	AC24BK U24
Operation Range	Cooling	Min. / Max.	°C DB	-10 / 48	-10 / 48	-15 / 48	-15 / 48
	Heating	Min. / Max.	°C DB	-10 / 24	-10 / 24	-10 / 24	-10 / 24
Sound Pressure*	Cooling / Heating	High	dB(A)	48 / 50	48 / 50	53 / 55	54 / 57
	Cooling	High	dB(A)	65	65	65	70
Air Flow Rate	Cooling	High	m ³ /min	27	27	35	49
	Liquid (ODU / IDU)	Min. / Max.	m	3 / 15	3 / 15	3 / 20	3 / 30
Piping	Elevation (ODU / IDU)	Min. / Max.	m	7	7	10	15
	Liquid	OD (Outside)	mm (inch)	6.35 (1/4)	6.35 (1/4)	6.35 (1/4)	6.35 (1/4)
Piping Connection	Gas	OD (Outside)	mm (inch)	9.52 (3/8)	9.52 (3/8)	12.7 (1/2)	15.88 (5/8)
	Drain Hose Size	OD (Outside)	mm (inch)	21.5 (27/32)	21.5 (27/32)	21.5 (27/32)	21.5 (27/32)
Refrigerant	Type			R32	R32	R32	R32
	Charge at 7.5m		kg	0.700	0.700	1.000	1.100
	Additional Charge		t-CO ₂ eq	0.473	0.473	0.675	0.743
	GWP		g/m	20	20	20	20
Fan Motor Output			W	675	675	675	675
Compressor Type				43	43	43	85
Net Weight			kg	25.1	25.1	34.4	46.0
Dimension			mm	717 x 495 x 230	717 x 495 x 230	770 x 545 x 288	870 x 650 x 330
ACCESSORIES & OTHERS							
Multi Compatible				Y	Y	Y	Y
PI 485				-	-	-	-
Dry Contact				Y	Y	Y	Y
Wired Remote Controller				Y	Y	Y	Y

* : Sound Pressure is not a value declared on Eurovent Program.
 ※ This product contains Fluorinated greenhouse gases (R32).
 ※ S : Sleep / L : Low / M : Medium / H : High
 ※ GWP : Global warming potential
 ※ t-CO₂eq : F-gas(kg)*GWP/1000
 ※ For our policy of continuous product improvement, specification, design and feature are subject to change without prior notice.
 ※ Y : Available or Applied / - : Not Available or Not Applied

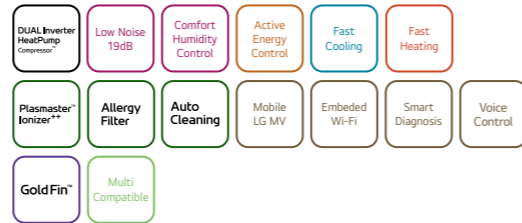

LG participates in the ECP programme for EUROVENT AC program. Check ongoing validity of certification : www.eurovent-certification.com

Single Combination

UNIT				9K	12K
INDOOR				F09MT NSM	F12MT NSM
Capacity	Cooling	Min. / Rated / Max.	kW	0.30 / 2.50 / 4.00	0.30 / 3.50 / 4.25
	Heating	Min. / Rated / Max.	kW	0.30 / 3.20 / 6.90	0.30 / 4.00 / 7.32
Power Input	Heating -7°C	Rated	kW	4.30	4.70
	Cooling / Heating	Rated	W	490 / 593	833 / 785
EER			W/W	5.10	4.20
S.E.E.R.				9.40	9.10
P design C			kW	2.50	3.50
COP			W/W	5.40	5.10
S.C.O.P		(Average / Warmer)		5.10 / 6.60	5.10 / 6.60
P design H (Average / Warmer)			kW	3.70 / 2.05	3.80 / 2.05
Energy Label (A+++ to D Scale)	Cooling			A+++	A+++
	Heating	(Average / Warmer)		A+++ / A+++	A+++ / A+++
Annual Energy Consumption	Cooling		kWh	93	135
	Heating	Average	kWh	1,016	1,043
Sound Pressure*	Cooling	S / L / M / H	dB(A)	19 / 27 / 35 / 40	19 / 27 / 35 / 40
	Heating	L / M / H	dB(A)	27 / 35 / 40	27 / 35 / 40
Sound Power	Cooling		dB(A)	60	60
	Heating	S / L / M / H / Max. (Power)	m ³ /min	6.6 / 8.7 / 11.1 / 12.4 / 15.5	6.6 / 8.7 / 11.1 / 12.4 / 15.5
Air Flow Rate	Cooling	L / M / H	m ³ /min	8.7 / 11.1 / 14.3	8.7 / 11.1 / 14.3
	Heating		l/h	1.7	1.7
Running Current	Cooling	Min. / Rated / Max.	A	0.70 / 3.80 / 8.10	0.70 / 6.10 / 8.10
	Heating	Min. / Rated / Max.	A	1.05 / 4.60 / 8.80	1.05 / 5.80 / 8.80
Starting Current	Cooling / Heating	Rated	A	3.80 / 4.60	6.10 / 5.80
Power Supply			Ø / V / Hz	1 / 220-240 / 50	1 / 220-240 / 50
Circuit Breaker			A	15	15
Power Supply Cable			N x mm ²	3 x 1.0	3 x 1.0
Power & Transmission Cable			N x mm ²	4 x 1.0 (Including Earth)	4 x 1.0 (Including Earth)
Dimension			mm	875 x 295 x 235	875 x 295 x 235
Net Weight			kg	11.0	11.0
Fan Motor Output			W	30	30
OUTDOOR				F09MT U24	F12MT U24
Operation Range	Cooling	Min. / Max.	°C DB	-10 / 48	-10 / 48
	Heating	Min. / Max.	°C DB	-25 / 24	-25 / 24
Sound Pressure*	Cooling / Heating	High	dB(A)	48 / 50	48 / 50
Sound Power	Cooling	High	dB(A)	65	65
Air Flow Rate		High	m ³ /min	49	49
Piping	Liquid (ODU / IDU)	Min. / Max.	m	3 / 20	3 / 20
	Elevation (ODU / IDU)	Min. / Max.	m	10	10
Piping Connection	Liquid	OD (Outside)	mm (inch)	6.35 (1/4)	6.35 (1/4)
	Gas	OD (Outside)	mm (inch)	9.52 (3/8)	9.52 (3/8)
Drain Hose Size		OD (Outside)	mm (inch)	21.5 (27/32)	21.5 (27/32)
Refrigerant	Type			R32	R32
	Charge at 7.5m		kg	1.000	1.000
	Additional Charge		t-CO ₂ eq	0.675	0.675
	GWP		g/m	20	20
Fan Motor Output			W	675	675
Compressor Type				85	85
Compressor Type				Inverter Twin Rotary	Inverter Twin Rotary
Net Weight			kg	43.0	43.0
Dimension			mm	870 x 650 x 330	870 x 650 x 330
ACCESSORIES & OTHERS					
Multi Compatible				-	-
PI 485				-	-
Dry Contact				Y	Y
Wired Remote Controller				Y	Y

* : Sound Pressure is not a value declared on Eurovent Program.
 ※ This product contains Fluorinated greenhouse gases (R32).
 ※ S : Sleep / L : Low / M : Medium / H : High
 ※ GWP : Global warming potential
 ※ t-CO₂eq : F-gas(kg)*GWP/1000
 ※ For our policy of continuous product improvement, specification, design and feature are subject to change without prior notice.
 ※ Y : Available or Applied / - : Not Available or Not Applied

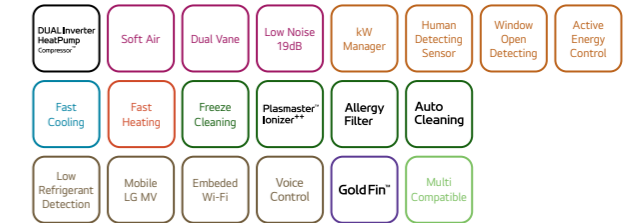

LG participates in the ECP programme for EUROVENT AC program. Check ongoing validity of certification : www.eurovent-certification.com

Single Combination

UNIT				9K	12K
INDOOR				H09S1P.NS1	H12S1P.NS1
Capacity	Cooling	Min. / Rated / Max.	kW	0.89 / 2.50 / 4.00	0.89 / 3.50 / 4.35
	Heating	Min. / Rated / Max.	kW	0.65 / 3.20 / 5.50	0.65 / 4.00 / 6.00
Power Input	Heating -7°C	Rated	kW	3.60	4.00
	Cooling / Heating	Rated	W	510 / 640	815 / 850
EER			W/W	4.29	4.29
S.E.E.R.				9.7	9.5
P design C			kW	2.5	3.5
COP			W/W	5.00	4.71
S.C.O.P		(Average / Warmer)		5.10 / 6.10	5.10 / 6.10
P design H (Average / Warmer)			kW	2.8	2.8
Energy Label (A+++ to D Scale)	Cooling			A+++	A+++
	Heating	(Average / Warmer)		A+++ / A+++	A+++ / A+++
Annual Energy Consumption	Cooling		kWh	90	129
	Heating	(Average / Warmer)	kWh	769 / 344	769 / 344
Sound Pressure*	Cooling	S / L / M / H	dB(A)	19 / 27 / 35 / 40	19 / 27 / 35 / 40
	Heating	L / M / H	dB(A)	27 / 35 / 40	27 / 35 / 40
Sound Power	Cooling		dB(A)	60	60
	Heating	S / L / M / H / Max. (Power)	m ³ /min	2.0 / 5.7 / 8.1 / 10.5 / 13.6	2.0 / 5.7 / 8.1 / 10.5 / 13.6
Air Flow Rate	Cooling	L / M / H	m ³ /min	5.7 / 8.1 / 10.5	5.7 / 8.1 / 10.5
	Heating		l/h	1.15	1.30
Running Current	Cooling	Min. / Rated / Max.	A	1.3 / 3.1 / 6.0	1.3 / 3.75 / 6.5
	Heating	Min. / Rated / Max.	A	1.3 / 3.2 / 7.0	1.3 / 4.0 / 7.5
Starting Current	Cooling / Heating	Rated	A	3.1 / 3.2	3.75 / 4.0
Power Supply			Ø / V / Hz	1 / 220-240 / 50	1 / 220-240 / 50
Circuit Breaker			A	15	15
Power Supply Cable			N x mm ²	3 x 1.0	3 x 1.0
Power & Transmission Cable			N x mm ²	4 x 1.0 (Including Earth)	4 x 1.0 (Including Earth)
Dimension			mm	895 x 307 x 235	895 x 307 x 235
Net Weight			kg	12.5	12.5
Fan Motor Output			W	30	30
OUTDOOR				H09S1PU18	H12S1PU18
Operation Range	Cooling	Min. / Max.	°C DB	-15 / 48	-15 / 48
	Heating	Min. / Max.	°C DB	-15 / 24	-15 / 24
Sound Pressure*	Cooling / Heating	High	dB(A)	49 / 51	49 / 51
Sound Power	Cooling	High	dB(A)	65	65
Air Flow Rate		High	m ³ /min	35	35
Piping	Liquid (ODU / IDU)	Min. / Max.	m	3 / 20	3 / 20
	Elevation (ODU / IDU)	Min. / Max.	m	10	10
Piping Connection	Liquid	OD (Outside)	mm (inch)	6.35 (1/4)	6.35 (1/4)
	Gas	OD (Outside)	mm (inch)	9.52 (3/8)	9.52 (3/8)
Drain Hose Size		OD (Outside)	mm (inch)	21.5 (27/32)	21.5 (27/32)
Refrigerant	Type			R32	R32
	Charge at 7.5m		kg	0.900	0.900
	Additional Charge		t-CO ₂ eq	0.608	0.608
	GWP		g/m	20	20
Fan Motor Output			W	675	675
Compressor Type				43	43
Compressor Type				Twin Rotary	Twin Rotary
Net Weight			kg	29.9	29.9
Dimension			mm	770 x 545 x 288	770 x 545 x 288
ACCESSORIES & OTHERS					
Multi Compatible				Y	Y
PI 485				Y	Y
Dry Contact				Y	Y
Wired Remote Controller				Y	Y

* : Sound Pressure is not a value declared on Eurovent Program.
 ※ This product contains Fluorinated greenhouse gases (R32).
 ※ S : Sleep / L : Low / M : Medium / H : High
 ※ GWP : Global warming potential
 ※ t-CO₂eq : F-gas(kg)*GWP/1000
 ※ For our policy of continuous product improvement, specification, design and feature are subject to change without prior notice.
 ※ Y : Available or Applied / - : Not Available or Not Applied

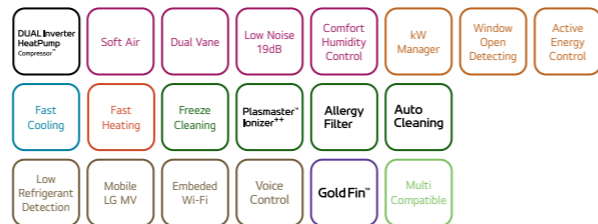

LG participates in the ECP programme for EUROVENT AC program. Check ongoing validity of certification : www.eurovent-certification.com

Single Combination

UNIT				9K	12K	18K	24K
INDOOR				H09S1D.NS1	H12S1D.NS1	H18S1D.NS1	H24S1D.NS1
Capacity	Cooling	Min. / Rated / Max.	kW	0.89 / 2.50 / 3.80	0.89 / 3.50 / 4.20	0.90 / 5.00 / 5.50	0.90 / 6.60 / 7.42
	Heating	Min. / Rated / Max.	kW	0.65 / 3.20 / 4.90	0.65 / 4.00 / 5.40	0.90 / 5.80 / 6.40	0.90 / 7.50 / 8.64
Power Input	Cooling / Heating	Rated	W	555 / 700	890 / 920	1,545 / 1,560	2,164 / 2,238
	Heating -7°C	Rated	kW	3.30	3.60	4.20	6.00
EER	Cooling / Heating	Rated	W/W	4.50	3.93	3.24	3.05
S.E.E.R.	Cooling / Heating	Rated	W/W	8.70	8.50	7.00	6.90
P design C	Cooling / Heating	Rated	kW	2.50	3.50	5.00	6.60
COP	Cooling / Heating	Rated	W/W	4.57	4.35	3.72	3.35
S.C.O.P	(Average / Warmer)	Rated	W/W	4.60 / 5.70	4.60 / 5.70	4.30 / 5.60	4.30 / 5.60
P design H (Average / Warmer)	Cooling / Heating	Rated	kW	2.80	2.80	3.90	5.00
Energy Label (A+++ to D Scale)	Cooling	Rated	A	A+++	A+++	A++	A++
Annual Energy Consumption	Cooling	(Average / Warmer)	kWh	103	144	250	335
	Heating	(Average / Warmer)	kWh	852 / 368	852 / 368	1,270 / 525	1,628 / 675
Sound Pressure*	Cooling	S / L / M / H	dB(A)	19 / 27 / 35 / 40	19 / 27 / 37 / 40	29 / 34 / 42 / 47	29 / 34 / 42 / 47
	Heating	L / M / H	dB(A)	27 / 35 / 40	27 / 35 / 40	34 / 42 / 47	34 / 42 / 47
Sound Power	Cooling	S / L / M / H / Max. (Power)	dB(A)	2.0 / 5.7 / 8.1 / 10.5 / 13.6	2.0 / 5.7 / 8.1 / 10.5 / 13.6	- / 8.1 / 9.9 / 11.7 / 13.6	- / 8.1 / 9.9 / 11.7 / 14.8
	Heating	L / M / H	dB(A)	5.7 / 8.1 / 10.5	5.7 / 8.1 / 10.5	8.1 / 9.9 / 11.7	8.1 / 11.1 / 13.6
Dehumidification Rate	Cooling	Min. / Rated / Max.	l/h	1.15	1.3	1.8	2.5
	Heating	Min. / Rated / Max.	l/h	1.5 / 2.6 / 5.5	1.5 / 4.1 / 6.1	1.6 / 6.9 / 9.0	1.6 / 9.8 / 14.0
Running Current	Cooling	Min. / Rated / Max.	A	1.5 / 3.2 / 6.3	1.5 / 4.25 / 7.0	1.6 / 7.0 / 9.5	1.6 / 10.0 / 14.0
	Heating	Min. / Rated / Max.	A	2.6 / 3.2	4.10 / 4.25	6.9 / 7.0	9.8 / 10.0
Starting Current	Cooling / Heating	Rated	A	2.6 / 3.2	4.10 / 4.25	6.9 / 7.0	9.8 / 10.0
Power Supply	Ø / V / Hz	Rated	Ø / V / Hz	1 / 220-240 / 50	1 / 220-240 / 50	1 / 220-240 / 50	1 / 220-240 / 50
Circuit Breaker	A	Rated	A	15	15	15	20
Power Supply Cable	N x mm ²	Rated	N x mm ²	3 x 1.0	3 x 1.0	3 x 1.0	3 x 2.5
Power & Transmission Cable	N x mm ²	Rated	N x mm ²	4 x 1.0	4 x 1.0	4 x 1.0	4 x 1.0
Dimension	mm	Rated	mm	895 X 307 X 235	895 x 307 x 235	895 x 307 x 235	895 x 307 x 235
Net Weight	kg	Rated	kg	11.0	11.0	12.5	12.5
Fan Motor Output	W	Rated	W	30	30	30	30
OUTDOOR				H09S1D.U12	H12S1D.U12	H18S1D.U18	H24S1D.U24
Operation Range	Cooling	Min. / Max.	°C DB	-15 / 48	-15 / 48	-15 / 48	-15 / 48
	Heating	Min. / Max.	°C DB	-10 / 24	-10 / 24	-10 / 24	-10 / 24
Sound Pressure*	Cooling / Heating	High	dB(A)	49 / 51	49 / 51	53 / 55	54 / 57
Sound Power	Cooling	High	dB(A)	65	65	65	70
Air Flow Rate	Cooling	High	m ³ /min	27	27	35	49
Piping	Liquid (ODU / IDU)	Min. / Max.	m	3 / 20	3 / 20	3 / 20	3 / 20
	Elevation (ODU / IDU)	Min. / Max.	m	7	7	10	15
Piping Connection	Liquid	OD (Outside)	mm (inch)	6.35 (1/4)	6.35 (1/4)	6.35 (1/4)	6.35 (1/4)
	Gas	OD (Outside)	mm (inch)	9.52 (3/8)	9.52 (3/8)	12.7 (1/2)	15.88 (5/8)
Drain Hose Size	OD (Outside)	mm (inch)	mm (inch)	21.5 (27/32)	21.5 (27/32)	21.5 (27/32)	21.5 (27/32)
Refrigerant	Type		kg	R32	R32	R32	R32
	Charge at 7.5m		kg	0.800	0.800	1.050	1.150
	t-CO ₂ eq		g/m	0.540	0.540	0.710	0.780
	Additional Charge		g/m	20	20	20	20
GWP				675	675	675	675
Fan Motor Output	W	Rated	W	43	43	43	85
Compressor Type				Twin Rotary	Twin Rotary	Twin Rotary	Inverter Twin Rotary
Net Weight	kg	Rated	kg	25.1	25.1	34.4	46.0
Dimension	mm	Rated	mm	717 x 495 x 230	717 x 495 x 230	770 x 545 x 288	870 x 650 x 330
ACCESSORIES & OTHERS							
Multi Compatible				Y	Y	Y	Y
PI 485				N	N	Y	Y
Dry Contact				Y	Y	Y	Y
Wired Remote Controller				Y	Y	Y	Y

Preliminary Data Only

* : Sound Pressure is not a value declared on Eurovent Program.
 ※ This product contains Fluorinated greenhouse gases (R32).
 ※ S : Sleep / L : Low / M : Medium / H : High
 ※ GWP : Global warming potential
 ※ t-CO₂eq : F-gas(kg)*GWP/1000
 ※ For our policy of continuous product improvement, specification, design and feature are subject to change without prior notice.
 ※ Y : Available or Applied / - : Not Available or Not Applied

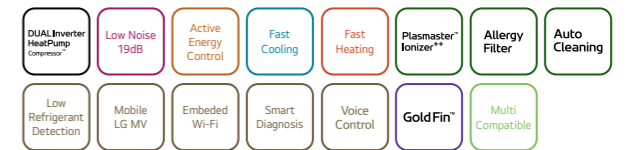

LG participates in the ECP programme for EUROVENT AC program. Check ongoing validity of certification : www.eurovent-certification.com

Single Combination

UNIT				9K	12K	18K	24K
INDOOR				DC09RK NSJ	DC12RK NSJ	DC18RK NSK	DC24RK NSK
Capacity	Cooling	Min. / Rated / Max.	kW	0.89 / 2.50 / 3.70	0.89 / 3.50 / 4.04	0.90 / 5.00 / 5.50	0.90 / 6.60 / 7.42
	Heating	Min. / Rated / Max.	kW	0.89 / 3.20 / 5.00	0.89 / 4.00 / 6.00	0.90 / 5.80 / 6.40	0.90 / 7.50 / 8.64
Power Input	Cooling / Heating	Rated	W	572 / 711	933 / 976	1,562 / 1,611	2,164 / 2,238
	Heating -7°C	Rated	kW	3.20	3.50	4.20	6.00
EER	Cooling / Heating	Rated	W/W	4.37	3.75	3.20	3.05
S.E.E.R.	Cooling / Heating	Rated	W/W	7.90	7.60	7.00	6.90
P design C	Cooling / Heating	Rated	kW	2.50	3.50	5.00	6.60
COP	Cooling / Heating	Rated	W/W	4.50	4.10	3.60	3.35
S.C.O.P	(Average / Warmer)	Rated	W/W	4.60 / 5.40	4.60 / 5.40	4.30 / 5.30	4.30 / 5.30
P design H (Average / Warmer)	Cooling / Heating	Rated	kW	2.80 / 1.50	2.90 / 1.50	3.90 / 2.10	5.00 / 2.70
Energy Label (A+++ to D Scale)	Cooling	Rated	A	A++	A++	A++	A++
Annual Energy Consumption	Cooling	(Average / Warmer)	kWh	111	161	250	335
	Heating	(Average / Warmer)	kWh	852 / 389	883 / 389	1,270 / 555	1,628 / 713
Sound Pressure*	Cooling	S / L / M / H	dB(A)	19 / 27 / 37 / 42	19 / 27 / 37 / 42	31 / 34 / 39 / 44	31 / 34 / 42 / 47
	Heating	L / M / H	dB(A)	27 / 37 / 42	27 / 37 / 42	34 / 39 / 44	34 / 42 / 47
Sound Power	Cooling	S / L / M / H / Max. (Power)	dB(A)	3.5 / 5.5 / 9.0 / 11.0 / 13.0	3.5 / 5.5 / 9.0 / 11.0 / 13.0	8.0 / 10.5 / 13.0 / 14.5 / 15.5	8.0 / 10.5 / 13.1 / 14.8
	Heating	L / M / H	dB(A)	6.5 / 9.0 / 11.0	6.5 / 9.0 / 11.0	11.0 / 13.5 / 16.0	11.0 / 14.3 / 17.6
Dehumidification Rate	Cooling	Min. / Rated / Max.	l/h	1.1	1.3	1.8	2.5
	Heating	Min. / Rated / Max.	l/h	1.00 / 2.50 / 6.00	1.00 / 4.00 / 6.00	1.20 / 6.90 / 9.00	1.20 / 9.80 / 14.00
Running Current	Cooling	Min. / Rated / Max.	A	1.00 / 3.20 / 7.00	1.00 / 4.30 / 7.00	1.20 / 7.10 / 9.50	1.20 / 10.00 / 14.00
	Heating	Min. / Rated / Max.	A	2.50 / 3.20	4.00 / 4.30	6.90 / 7.10	9.80 / 10.00
Starting Current	Cooling / Heating	Rated	A	2.50 / 3.20	4.00 / 4.30	6.90 / 7.10	9.80 / 10.00
Power Supply	Ø / V / Hz	Rated	Ø / V / Hz	1 / 220-240 / 50	1 / 220-240 / 50	1 / 220-240 / 50	1 / 220-240 / 50
Circuit Breaker	A	Rated	A	15	15	20	25
Power Supply Cable	N x mm ²	Rated	N x mm ²	3 x 1.0	3 x 1.0	3 x 1.5	3 x 2.5
Power & Transmission Cable	N x mm ²	Rated	N x mm ²	4 x 1.0	4 x 1.0	4 x 1.0	4 x 1.0
Dimension	mm	Rated	mm	837 x 308 x 189	837 x 308 x 189	998 x 345 x 210	998 x 345 x 210
Net Weight	kg	Rated	kg	9.1	9.1	11.9	12.7
Fan Motor Output	W	Rated	W	30	30	30	58
OUTDOOR				DC09RK UL2	DC12RK UL2	DC18RK UL2	DC24RK U24
Operation Range	Cooling	Min. / Max.	°C DB	-15 / 48	-15 / 48	-15 / 48	-15 / 48
	Heating	Min. / Max.	°C DB	-15 / 24	-15 / 24	-10 / 24	-10 / 24
Sound Pressure*	Cooling / Heating	High	dB(A)	49 / 51	49 / 51	53 / 55	54 / 57
Sound Power	Cooling	High	dB(A)	65	65	65	70
Air Flow Rate	Cooling	High	m ³ /min	35	35	35	49
Piping	Liquid (ODU / IDU)	Min. / Max.	m	3 / 20	3 / 20	3 / 20	3 / 30
	Elevation (ODU / IDU)	Min. / Max.	m	10	10	10	15
Piping Connection	Liquid	OD (Outside)	mm (inch)	6.35 (1/4)	6.35 (1/4)	6.35 (1/4)	6.35 (1/4)
	Gas	OD (Outside)	mm (inch)	9.52 (3/8)	9.52 (3/8)	12.7 (1/2)	15.88 (5/8)
Drain Hose Size	OD (Outside)	mm (inch)	mm (inch)	21.5 (27/32)	21.5 (27/32)	21.5 (27/32)	21.5 (27/32)
Refrigerant	Type		kg	R32	R32	R32	R32
	Charge at 7.5m		kg	0.800	0.800	1.000	1.100
	t-CO ₂ eq		g/m	0.540	0.540	0.675	0.743
	Additional Charge		g/m	20	20	20	20
GWP				675	675	675	675
Fan Motor Output	W	Rated	W	43	43	43	85
Compressor Type				Inverter Twin Rotary	Inverter Twin Rotary	Inverter Twin Rotary	Inverter Twin Rotary
Net Weight	kg	Rated	kg	34.1	34.1	34.4	46.0
Dimension	mm	Rated	mm	770 x 545 x 288	770 x 545 x 288	770 x 545 x 288	870 x 650 x 330
ACCESSORIES & OTHERS							
Multi Compatible				Y	Y	Y	Y
PI 485				Y	Y	Y	Y
Dry Contact				Y	Y	Y	Y
Wired Remote Controller				Y	Y	Y	Y

* : Sound Pressure is not a value declared on Eurovent Program.
 ※ This product contains Fluorinated greenhouse gases (R32).
 ※ S : Sleep / L : Low / M : Medium / H : High
 ※ GWP : Global warming potential
 ※ t-CO₂eq : F-gas(kg)*GWP/1000
 ※ For our policy of continuous product improvement, specification, design and feature are subject to change without prior notice.
 ※ Y : Available or Applied / - : Not Available or Not Applied

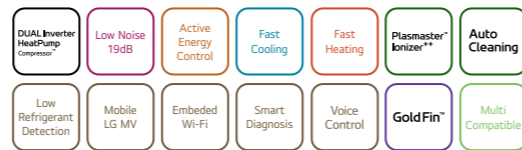

LG participates in the ECP programme for EUROVENT AC program. Check ongoing validity of certification : www.eurovent-certification.com

Single Combination

UNIT				9K	12K
INDOOR				DC09RT NSJ	DC12RT NSJ
Capacity	Cooling	Min. / Rated / Max.	kW	0.89 / 2.50 / 3.70	0.89 / 3.50 / 4.04
	Heating	Min. / Rated / Max.	kW	0.89 / 3.30 / 4.10	0.89 / 4.00 / 5.10
	Heating -7°C	Rated	kW	2.60	3.00
Power Input	Cooling / Heating	Rated	W	656 / 800	1,080 / 1,050
EER			W/W	3.81	3.24
S.E.E.R.				7.00	6.60
P design C			kW	2.50	3.50
COP			W/W	4.13	3.81
S.C.O.P		(Average / Warmer)		4.00 / 4.90	4.00 / 4.90
P design H (Average / Warmer)			kW	2.50 / 1.30	2.50 / 1.30
Energy Label (A+++ to D Scale)	Cooling			A++	A++
	Heating	(Average / Warmer)		A+ / A++	A+ / A++
Annual Energy Consumption	Cooling		kWh	125	186
	Heating	(Average / Warmer)	kWh	875 / 371	875 / 371
Sound Pressure*	Cooling	S / L / M / H	dB(A)	19 / 27 / 35 / 41	19 / 27 / 35 / 41
	Heating	L / M / H	dB(A)	27 / 35 / 41	27 / 35 / 41
Sound Power	Cooling		dB(A)	59	59
	Heating	S / L / M / H / Max. (Power)	m ² /min	3.0 / 4.2 / 7.5 / 10.0 / 12.5	3.0 / 4.2 / 7.5 / 10.0 / 12.5
Air Flow Rate	Cooling	L / M / H	m ³ /min	5.6 / 7.2 / 10.0	5.6 / 7.2 / 10.0
	Heating				
Dehumidification Rate			l/h	1.1	1.3
Running Current	Cooling	Min. / Rated / Max.	A	1.10 / 3.30 / 6.00	1.10 / 4.70 / 6.00
	Heating	Min. / Rated / Max.	A	1.10 / 4.00 / 7.00	1.10 / 4.70 / 7.00
Starting Current	Cooling / Heating	Rated	A	3.30 / 4.00	4.70 / 4.70
Power Supply			Ø / V / Hz	1 / 220-240 / 50	1 / 220-240 / 50
Circuit Breaker			A	15	15
Power Supply Cable			N x mm ²	3 x 1.0	3 x 1.0
Power & Transmission Cable			N x mm ²	4 x 1.0 (Including Earth)	4 x 1.0 (Including Earth)
Dimension			mm	837 x 308 x 189	837 x 308 x 189
Net Weight			kg	9.1	9.1
Fan Motor Output			W	30	30
OUTDOOR				DC09RT UA3	DC12RT UA3
Operation Range	Cooling	Min. / Max.	°C DB	-10 / 48	-10 / 48
	Heating	Min. / Max.	°C DB	-10 / 24	-10 / 24
Sound Pressure*	Cooling / Heating	High	dB(A)	48 / 50	48 / 50
Sound Power	Cooling	High	dB(A)	65	65
Air Flow Rate		High	m ³ /min	27	27
Piping	Liquid (ODU / IDU)	Min. / Max.	m	3 / 15	3 / 15
	Elevation (ODU / IDU)	Min. / Max.	m	7	7
Piping Connection	Liquid	OD (Outside)	mm (inch)	6.35 (1/4)	6.35 (1/4)
	Gas	OD (Outside)	mm (inch)	9.52 (3/8)	9.52 (3/8)
Drain Hose Size		OD (Outside)	mm (inch)	21.5 (27/32)	21.5 (27/32)
Refrigerant	Type			R32	R32
	Charge at 7.5m		kg	0.700	0.700
	Additional Charge		t-CO ₂ eq	0.473	0.473
	GWP		g/m	20	20
Fan Motor Output			W	675	675
Compressor Type				43	43
Net Weight			kg	25.1	25.1
Dimension			mm	717 x 495 x 230	717 x 495 x 230
ACCESSORIES & OTHERS					
Multi Compatible				Y	Y
PI 485				Y	Y
Dry Contact				Y	Y
Wired Remote Controller				Y	Y

* : Sound Pressure is not a value declared on Eurovent Program.
 ※ This product contains Fluorinated greenhouse gases (R32).
 ※ S : Sleep / L : Low / M : Medium / H : High
 ※ GWP : Global warming potential
 ※ t-CO₂eq : F-gas(kg)*GWP/1000
 ※ For our policy of continuous product improvement, specification, design and feature are subject to change without prior notice.
 ※ Y : Available or Applied / - : Not Available or Not Applied

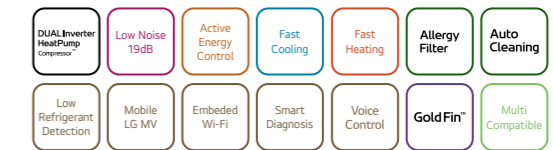

LG participates in the ECP programme for EUROVENT AC program. Check ongoing validity of certification : www.eurovent-certification.com

Single Combination

UNIT				9K	12K	18K	24K
INDOOR				PC09SK NSJ	PC12SK NSJ	PC18SK NSK	PC24SK NSK
Capacity	Cooling	Min. / Rated / Max.	kW	0.89 / 2.50 / 3.70	0.89 / 3.50 / 4.04	0.90 / 5.00 / 5.50	0.90 / 6.60 / 7.42
	Heating	Min. / Rated / Max.	kW	0.89 / 3.30 / 4.10	0.89 / 4.00 / 5.10	0.90 / 5.80 / 6.40	0.90 / 7.50 / 8.64
	Heating -7°C	Rated	kW	2.60	3.00	4.20	6.00
Power Input	Cooling / Heating	Rated	W	656 / 800	1,080 / 1,050	1,562 / 1,611	2,164 / 2,238
EER			W/W	3.81	3.24	3.20	3.05
S.E.E.R.				7.00	6.60	7.00	6.90
P design C			kW	2.50	3.50	5.00	6.60
COP			W/W	4.13	3.81	3.60	3.35
S.C.O.P		(Average / Warmer)		4.00 / 4.90	4.00 / 4.90	4.30 / 5.30	4.30 / 5.30
P design H (Average / Warmer)			kW	2.50 / 1.30	2.50 / 1.30	3.90 / 2.10	5.00 / 2.70
Energy Label (A+++ to D Scale)	Cooling			A++	A++	A++	A++
	Heating	(Average / Warmer)		A+ / A++	A+ / A++	A+ / A+++	A+ / A+++
Annual Energy Consumption	Cooling		kWh	125	186	250	335
	Heating	(Average / Warmer)	kWh	875 / 371	875 / 371	1,270 / 555	1,628 / 713
Sound Pressure*	Cooling	S / L / M / H	dB(A)	19 / 27 / 35 / 41	19 / 27 / 35 / 41	31 / 34 / 39 / 44	31 / 34 / 42 / 47
	Heating	L / M / H	dB(A)	27 / 35 / 41	27 / 35 / 41	34 / 39 / 44	34 / 42 / 47
Sound Power	Cooling		dB(A)	59	59	60	65
	Heating	S / L / M / H / Max. (Power)	m ² /min	3.0 / 4.2 / 7.5 / 10.0 / 12.5	3.0 / 4.2 / 7.5 / 10.0 / 12.5	8.0 / 10.5 / 13.0 / 14.5 / 15.5	8.0 / 10.5 / 13.1 / 14.3 / 17.6
Air Flow Rate	Cooling	L / M / H	m ³ /min	5.6 / 7.2 / 10.0	5.6 / 7.2 / 10.0	11.0 / 13.5 / 16.0	11.0 / 14.3 / 17.6
	Heating						
Dehumidification Rate			l/h	1.1	1.3	1.8	2.5
Running Current	Cooling	Min. / Rated / Max.	A	1.10 / 3.30 / 6.00	1.10 / 4.70 / 6.00	1.20 / 6.90 / 9.00	1.20 / 9.80 / 14.00
	Heating	Min. / Rated / Max.	A	1.10 / 4.00 / 7.00	1.10 / 4.70 / 7.00	1.20 / 7.10 / 9.50	1.20 / 10.00 / 14.00
Starting Current	Cooling / Heating	Rated	A	3.30 / 4.00	4.70 / 4.70	6.90 / 7.10	9.80 / 10.00
Power Supply			Ø / V / Hz	1 / 220-240 / 50	1 / 220-240 / 50	1 / 220-240 / 50	1 / 220-240 / 50
Circuit Breaker			A	15	15	20	25
Power Supply Cable			N x mm ²	3 x 1.0	3 x 1.0	3 x 1.5	3 x 2.5
Power & Transmission Cable			N x mm ²	4 x 1.0 (Including Earth)	4 x 1.0 (Including Earth)	4 x 1.0 (Including Earth)	4 x 1.0 (Including Earth)
Dimension			mm	837 x 308 x 189	837 x 308 x 189	998 x 345 x 210	998 x 345 x 210
Net Weight			kg	8.7	8.7	11.9	12.7
Fan Motor Output			W	30	30	30	58
OUTDOOR				PC09SK UA3	PC12SK UA3	PC18SK UL2	PC24SK U24
Operation Range	Cooling	Min. / Max.	°C DB	-10 / 48	-10 / 48	-15 / 48	-15 / 48
	Heating	Min. / Max.	°C DB	-10 / 24	-10 / 24	-10 / 24	-10 / 24
Sound Pressure*	Cooling / Heating	High	dB(A)	48 / 50	48 / 50	53 / 55	54 / 57
Sound Power	Cooling	High	dB(A)	65	65	65	70
Air Flow Rate		High	m ³ /min	27	27	35	49
Piping	Liquid (ODU / IDU)	Min. / Max.	m	3 / 15	3 / 15	3 / 20	3 / 30
	Elevation (ODU / IDU)	Min. / Max.	m	7	7	10	15
Piping Connection	Liquid	OD (Outside)	mm (inch)	6.35 (1/4)	6.35 (1/4)	6.35 (1/4)	6.35 (1/4)
	Gas	OD (Outside)	mm (inch)	9.52 (3/8)	9.52 (3/8)	12.7 (1/2)	15.88 (5/8)
Drain Hose Size		OD (Outside)	mm (inch)	21.5 (27/32)	21.5 (27/32)	21.5 (27/32)	21.5 (27/32)
Refrigerant	Type			R32	R32	R32	R32
	Charge at 7.5m		kg	0.700	0.700	1.000	1.100
	Additional Charge		t-CO ₂ eq	0.473	0.473	0.675	0.743
	GWP		g/m	20	20	20	20
Fan Motor Output			W	675	675	675	675
Compressor Type				43	43	43	85
Net Weight			kg	25.1	25.1	34.4	46.0
Dimension			mm	717 x 495 x 230	717 x 495 x 230	770 x 545 x 288	870 x 650 x 330
ACCESSORIES & OTHERS							
Multi Compatible				Y	Y	Y	Y
PI 485				-	-	-	-
Dry Contact				Y	Y	Y	Y
Wired Remote Controller				Y	Y	Y	Y

* : Sound Pressure is not a value declared on Eurovent Program.
 ※ This product contains Fluorinated greenhouse gases (R32).
 ※ S : Sleep / L : Low / M : Medium / H : High
 ※ GWP : Global warming potential
 ※ t-CO₂eq : F-gas(kg)*GWP/1000
 ※ For our policy of continuous product improvement, specification, design and feature are subject to change without prior notice.
 ※ Y : Available or Applied / - : Not Available or Not Applied

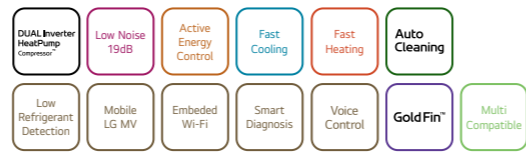

LG participates in the ECP programme for EUROVENT AC program. Check ongoing validity of certification : www.eurovent-certification.com

Single Combination

UNIT				9K	12K	18K	24K
INDOOR				S09ET NSJ	S12ET NSJ	S18ET NSK	S24ET NSK
Capacity	Cooling	Min. / Rated / Max.	kW	0.89 / 2.50 / 3.70	0.89 / 3.50 / 4.04	0.90 / 5.00 / 5.50	0.90 / 6.60 / 7.42
	Heating	Min. / Rated / Max.	kW	0.89 / 3.30 / 4.10	0.89 / 4.00 / 5.10	0.90 / 5.80 / 6.40	0.90 / 7.50 / 8.64
Power Input	Cooling / Heating	Rated	W	656 / 800	1,080 / 1,050	1,562 / 1,611	2,164 / 2,238
			W/W	3.81	3.24	3.20	3.05
S.E.E.R.				7.00	6.60	7.00	6.90
P design C			kW	2.50	3.50	5.00	6.60
COP			W/W	4.13	3.81	3.60	3.35
S.C.O.P		(Average / Warmer)		4.00 / 4.90	4.00 / 4.90	4.30 / 5.30	4.30 / 5.30
P design H (Average / Warmer)			kW	2.50 / 1.30	2.50 / 1.30	3.90 / 2.10	5.00 / 2.70
Energy Label (A+++ to D Scale)	Cooling			A++	A++	A++	A++
	Heating	(Average / Warmer)		A+ / A++	A+ / A++	A+ / A+++	A+ / A+++
Annual Energy Consumption	Cooling		kWh	125	186	250	335
	Heating	(Average / Warmer)	kWh	875 / 371	875 / 371	1,270 / 555	1,628 / 713
Sound Pressure*	Cooling	S / L / M / H	dB(A)	19 / 27 / 35 / 41	19 / 27 / 35 / 41	31 / 34 / 39 / 44	31 / 34 / 42 / 47
	Heating	L / M / H	dB(A)	27 / 35 / 41	27 / 35 / 41	34 / 39 / 44	34 / 42 / 47
Sound Power	Cooling		dB(A)	59	59	60	65
Air Flow Rate	Cooling	S / L / M / H / Max. (Power)	m ³ /min	3.0 / 4.2 / 7.5 / 10.0 / 12.5	3.0 / 4.2 / 7.5 / 10.0 / 12.5	8.0 / 10.5 / 13.0 / 14.5 / 15.5	8.0 / 10.5 / 13.1 / 16.1 / 18.3
	Heating	L / M / H	m ³ /min	5.6 / 7.2 / 10.0	5.6 / 7.2 / 10.0	11.0 / 13.5 / 16.0	11.0 / 14.3 / 17.6
Dehumidification Rate			l/h	1.1	1.3	1.8	2.5
Running Current	Cooling	Min. / Rated / Max.	A	1.10 / 3.30 / 6.00	1.10 / 4.70 / 6.00	1.20 / 6.90 / 9.00	1.20 / 9.80 / 14.00
	Heating	Min. / Rated / Max.	A	1.10 / 4.00 / 7.00	1.10 / 4.70 / 7.00	1.20 / 7.10 / 9.50	1.20 / 10.00 / 14.00
Starting Current	Cooling / Heating	Rated	A	3.30 / 4.00	4.70 / 4.70	6.90 / 7.10	9.80 / 10.00
Power Supply			Ø / V / Hz	1 / 220-240 / 50	1 / 220-240 / 50	1 / 220-240 / 50	1 / 220-240 / 50
Circuit Breaker			A	15	15	20	25
Power Supply Cable			N x mm ²	3 x 1.0	3 x 1.0	3 x 1.5	3 x 2.5
Power & Transmission Cable			N x mm ²	4 x 1.0 (Including Earth)	4 x 1.0 (Including Earth)	4 x 1.0 (Including Earth)	4 x 1.0 (Including Earth)
Dimension			mm	837 x 308 x 189	837 x 308 x 189	998 x 345 x 210	998 x 345 x 210
Net Weight			kg	8.7	8.7	11.9	12.7
Fan Motor Output			W	30	30	30	58
OUTDOOR				S09ET UA3	S12ET UA3	S18ET UL2	S24ET U24
Operation Range	Cooling	Min. / Max.	°C DB	-10 / 48	-10 / 48	-15 / 48	-15 / 48
	Heating	Min. / Max.	°C DB	-10 / 24	-10 / 24	-10 / 24	-10 / 24
Sound Pressure*	Cooling / Heating	High	dB(A)	48 / 50	48 / 50	53 / 55	54 / 57
Sound Power	Cooling	High	dB(A)	65	65	65	70
Air Flow Rate		High	m ³ /min	27	27	35	49
Piping	Liquid (ODU / IDU)	Min. / Max.	m	3 / 15	3 / 15	3 / 20	3 / 30
	Elevation (ODU / IDU)	Min. / Max.	m	7	7	10	15
Piping Connection	Liquid	OD (Outside)	mm (inch)	6.35 (1/4)	6.35 (1/4)	6.35 (1/4)	6.35 (1/4)
	Gas	OD (Outside)	mm (inch)	9.52 (3/8)	9.52 (3/8)	12.7 (1/2)	15.88 (5/8)
Drain Hose Size		OD (Outside)	mm (inch)	21.5 (27/32)	21.5 (27/32)	21.5 (27/32)	21.5 (27/32)
Refrigerant	Type			R32	R32	R32	R32
	Charge at 7.5m		kg	0.700	0.700	1.000	1.100
	Additional Charge		t-CO ₂ eq	0.473	0.473	0.675	0.743
	GWP		g/m	20	20	20	20
Fan Motor Output			W	675	675	675	675
Compressor Type				43	43	43	85
Net Weight			kg	25.1	25.1	34.4	46.0
Dimension			mm	717 x 495 x 230	717 x 495 x 230	770 x 545 x 288	870 x 650 x 330
ACCESSORIES & OTHERS							
Multi Compatible				Y	Y	Y	Y
PI 485				-	-	-	-
Dry Contact				Y	Y	Y	Y
Wired Remote Controller				Y	Y	Y	Y

* : Sound Pressure is not a value declared on Eurovent Program.
 ※ This product contains Fluorinated greenhouse gases (R32).
 ※ S : Sleep / L : Low / M : Medium / H : High
 ※ GWP : Global warming potential
 ※ t-CO₂eq : F-gas(kg)*GWP/1000
 ※ For our policy of continuous product improvement, specification, design and feature are subject to change without prior notice.
 ※ Y : Available or Applied / - : Not Available or Not Applied



LG participates in the ECP programme for EUROVENT AC program. Check ongoing validity of certification : www.eurovent-certification.com

Single Combination

UNIT				9K	12K	18K	24K
INDOOR				S09EQ NSJ	S12EQ NSJ	S18EQ NSK	S24EQ NSK
Capacity	Cooling	Min. / Rated / Max.	kW	0.89 / 2.50 / 3.70	0.89 / 3.50 / 4.04	0.90 / 5.00 / 5.50	0.90 / 6.60 / 7.42
	Heating	Min. / Rated / Max.	kW	0.89 / 3.30 / 4.10	0.89 / 4.00 / 5.10	0.90 / 5.80 / 6.40	0.90 / 7.50 / 8.64
Power Input	Cooling / Heating	Rated	W	656 / 800	1,080 / 1,050	1,562 / 1,611	2,164 / 2,238
			W/W	3.81	3.24	3.20	3.05
S.E.E.R.				7.00	6.60	7.00	6.90
P design C			kW	2.50	3.50	5.00	6.60
COP			W/W	4.13	3.81	3.60	3.35
S.C.O.P		(Average / Warmer)		4.00 / 4.90	4.00 / 4.90	4.30 / 5.30	4.30 / 5.30
P design H (Average / Warmer)			kW	2.50 / 1.30	2.50 / 1.30	3.90 / 2.10	5.00 / 2.70
Energy Label (A+++ to D Scale)	Cooling			A++	A++	A++	A++
	Heating	(Average / Warmer)		A+ / A++	A+ / A++	A+ / A+++	A+ / A+++
Annual Energy Consumption	Cooling		kWh	125	186	250	335
	Heating	(Average / Warmer)	kWh	875 / 371	875 / 371	1,270 / 555	1,628 / 713
Sound Pressure*	Cooling	S / L / M / H	dB(A)	19 / 27 / 35 / 41	19 / 27 / 35 / 41	31 / 34 / 39 / 44	31 / 34 / 42 / 47
	Heating	L / M / H	dB(A)	27 / 35 / 41	27 / 35 / 41	34 / 39 / 44	34 / 42 / 47
Sound Power	Cooling		dB(A)	59	59	60	65
Air Flow Rate	Cooling	S / L / M / H / Max. (Power)	m ³ /min	3.0 / 4.2 / 7.5 / 10.0 / 12.5	3.0 / 4.2 / 7.5 / 10.0 / 12.5	8.0 / 10.5 / 13.0 / 14.5 / 15.5	8.0 / 10.5 / 13.1 / 16.1 / 18.3
	Heating	L / M / H	m ³ /min	5.6 / 7.2 / 10.0	5.6 / 7.2 / 10.0	11.0 / 13.5 / 16.0	11.0 / 14.3 / 17.6
Dehumidification Rate			l/h	1.1	1.3	1.8	2.5
Running Current	Cooling	Min. / Rated / Max.	A	1.10 / 3.30 / 6.00	1.10 / 4.70 / 6.00	1.20 / 6.90 / 9.00	1.20 / 9.80 / 14.00
	Heating	Min. / Rated / Max.	A	1.10 / 4.00 / 7.00	1.10 / 4.70 / 7.00	1.20 / 7.10 / 9.50	1.20 / 10.00 / 14.00
Starting Current	Cooling / Heating	Rated	A	3.30 / 4.00	4.70 / 4.70	6.90 / 7.10	9.80 / 10.00
Power Supply			Ø / V / Hz	1 / 220-240 / 50	1 / 220-240 / 50	1 / 220-240 / 50	1 / 220-240 / 50
Circuit Breaker			A	15	15	20	25
Power Supply Cable			N x mm ²	3 x 1.0	3 x 1.0	3 x 1.5	3 x 2.5
Power & Transmission Cable			N x mm ²	4 x 1.0 (Including Earth)	4 x 1.0 (Including Earth)	4 x 1.0 (Including Earth)	4 x 1.0 (Including Earth)
Dimension			mm	837 x 308 x 189	837 x 308 x 189	998 x 345 x 210	998 x 345 x 210
Net Weight			kg	8.7	8.7	11.9	12.7
Fan Motor Output			W	30	30	30	58
OUTDOOR				S09EQ UA3	S12EQ UA3	S18EQ UL2	S24EQ U24
Operation Range	Cooling	Min. / Max.	°C DB	-10 / 48	-10 / 48	-15 / 48	-15 / 48
	Heating	Min. / Max.	°C DB	-10 / 24	-10 / 24	-10 / 24	-10 / 24
Sound Pressure*	Cooling / Heating	High	dB(A)	48 / 50	48 / 50	53 / 55	54 / 57
Sound Power	Cooling	High	dB(A)	65	65	65	70
Air Flow Rate		High	m ³ /min	27	27	35	49
Piping	Liquid (ODU / IDU)	Min. / Max.	m	3 / 15	3 / 15	3 / 20	3 / 30
	Elevation (ODU / IDU)	Min. / Max.	m	7	7	10	15
Piping Connection	Liquid	OD (Outside)	mm (inch)	6.35 (1/4)	6.35 (1/4)	6.35 (1/4)	6.35 (1/4)
	Gas	OD (Outside)	mm (inch)	9.52 (3/8)	9.52 (3/8)	12.7 (1/2)	15.88 (5/8)
Drain Hose Size		OD (Outside)	mm (inch)	21.5 (27/32)	21.5 (27/32)	21.5 (27/32)	21.5 (27/32)
Refrigerant	Type			R32	R32	R32	R32
	Charge at 7.5m		kg	0.700	0.700	1.000	1.100
	Additional Charge		t-CO ₂ eq	0.473	0.473	0.675	0.743
	GWP		g/m	20	20	20	20
Fan Motor Output			W	675	675	675	675
Compressor Type				43	43	43	85
Net Weight			kg	25.1	25.1	34.4	46.0
Dimension			mm	717 x 495 x 230	717 x 495 x 230	770 x 545 x 288	870 x 650 x 330
ACCESSORIES & OTHERS							
Multi Compatible				-	-	-	-
PI 485				-	-	-	-
Dry Contact				-	-	-	-
Wired Remote Controller				-	-	-	-

* : Sound Pressure is not a value declared on Eurovent Program.
 ※ This product contains Fluorinated greenhouse gases (R32).
 ※ S : Sleep / L : Low / M : Medium / H : High
 ※ GWP : Global warming potential
 ※ t-CO₂eq : F-gas(kg)*GWP/1000
 ※ For our policy of continuous product improvement, specification, design and feature are subject to change without prior notice.
 ※ Y : Available or Applied / - : Not Available or Not Applied



LG participates in the ECP programme for EUROVENT AC program. Check ongoing validity of certification : www.eurovent-certification.com

Single Combination

UNIT				9K	12K
INDOOR				W09TE.NEU	W12TE.NEU
Capacity	Cooling	Min. / Rated / Max.	kW	0.94 / 2.50 / 3.30	1.00 / 3.30 / 3.77
	Heating	Min. / Rated / Max.	kW	0.94 / 2.61 / 3.36	1.00 / 3.42 / 3.81
Power Input	Cooling / Heating	Rated	W	825 / 767	1,130 / 1,005
EER			W/W	3.03	2.92
S.E.E.R.				6.1	6.1
P design C			kW	2.5	3.3
COP			W/W	3.4	3.4
S.C.O.P		(Average / Warmer)		4.0 / 5.1	4.0 / 5.1
P design H (Average / Warmer)			kW	2.0 / 2.2	2.1 / 2.4
Energy Label	Cooling			A++	A++
(A+++ to D Scale)	Heating	(Average / Warmer)		A+ / A+++	A+ / A+++
Annual Energy	Cooling		kWh	143	189
Consumption	Heating	(Average / Warmer)	kWh	700 / 604	735 / 659
Sound Pressure*	Cooling	S / L / M / H	dB(A)	32 / 35 / 38 / 42	29 / 32 / 36 / 40
	Heating	L / M / H	dB(A)	35 / 38 / 42	31 / 35 / 40
Sound Power	Cooling		dB(A)	55	55
Air Flow Rate	Cooling	S / L / M / H / Max. (Power)	m ³ /min	3.9 / 4.3 / 4.7 / 5.6 / 6.1	4.6 / 5.2 / 6.1 / 7.3 / 8.1
	Heating	L / M / H	m ³ /min	4.8 / 5.3 / 6.3	7.2 / 8.0 / 9.2
Dehumidification Rate			l/h	1.0	1.2
Running Current	Cooling	Min. / Rated / Max.	A	1.2 / 4.0 / 8.0	1.5 / 5.8 / 9.0
	Heating	Min. / Rated / Max.	A	1.2 / 3.8 / 9.0	1.5 / 5.1 / 10.0
Power Supply			Ø / V / Hz	1 / 220-240 / 50	1 / 220-240 / 50
Power Supply Cable			N x mm ²	3 x 1.5	3 x 1.5
Power & Transmission Cable			N x mm ²	4 x 0.75 (Including Earth)	4 x 0.75 (Including Earth)
Dimension			mm	698 x 255 x 190	777 x 250 x 201
Net Weight			kg	7.0	7.8
OUTDOOR				W09TE.UEU	W12TE.UEU
Operation Range	Cooling	Min. / Max.	°C DB	-10 / 48	-10 / 48
	Heating	Min. / Max.	°C DB	-10 / 24	-10 / 24
Sound Pressure*	Cooling / Heating	High	dB(A)	52 / 53	54 / 54
Sound Power	Cooling	High	dB(A)	64	65
Air Flow Rate		High	m ³ /min	28.3	28.3
Piping	Liquid (ODU / IDU)	Min. / Max.	m	3 / 15	3 / 15
	Elevation (ODU / IDU)	Min. / Max.	m	10	10
Piping Connection	Liquid	OD (Outside)	mm (inch)	6.35 (1/4)	6.35 (1/4)
	Gas	OD (Outside)	mm (inch)	9.52 (3/8)	9.52 (3/8)
Drain Hose Size		OD (Outside)	mm (inch)	19.0 (3/4)	19.0 (3/4)
Refrigerant	Type			R32	R32
	Charge at 7.5m		kg	0.450	0.490
	Additional Charge		t-CO ₂ eq	0.304	0.331
	GWP			675	675
Compressor Type				Single Rotary	Single Rotary
Net Weight			kg	20.0	20.0
Dimension			mm	712 x 459 x 276	712 x 459 x 276
ACCESSORIES & OTHERS					
Multi Compatible				-	-
PI 485				-	-
Dry Contact				-	-
Wired Remote Controller				-	-

* : Sound Pressure is not a value declared on Eurovent Program.
 ※ This product contains Fluorinated greenhouse gases (R32).
 ※ S : Sleep / L : Low / M : Medium / H : High
 ※ GWP : Global warming potential
 ※ t-CO₂eq : F-gas(kg)*GWP/1000
 ※ For our policy of continuous product improvement, specification, design and feature are subject to change without prior notice.
 ※ Y : Available or Applied / - : Not Available or Not Applied

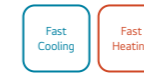

LG participates in the ECP programme for EUROVENT AC program. Check ongoing validity of certification : www.eurovent-certification.com

Single Combination

UNIT				9K	12K	18K	24K
INDOOR				W09TI.NEU	W12TI.NEU	W18TI.NEU	W24TI.NEU
Capacity	Cooling	Min. / Rated / Max.	kW	0.94 / 2.63 / 3.40	1.00 / 3.40 / 3.75	1.25 / 5.10 / 5.91	1.50 / 7.00 / 7.35
	Heating	Min. / Rated / Max.	kW	0.94 / 2.75 / 3.50	1.00 / 3.45 / 3.80	1.25 / 5.10 / 6.07	1.50 / 6.95 / 7.80
Power Input	Cooling / Heating	Rated	W	809 / 733	1,046 / 930	1,580 / 1,374	2,167 / 1,873
EER			W/W	3.25	3.25	3.23	3.23
S.E.E.R.				6.1	6.1	6.1	6.5
P design C			kW	2.6	3.4	5.1	7.0
COP			W/W	3.75	3.71	3.71	3.71
S.C.O.P		(Average / Warmer)		4.0 / 5.1	4.0 / 5.1	4.0 / 5.1	4.0 / 5.1
P design H (Average / Warmer)			kW	2.4 / 2.4	2.4 / 3.2	3.8 / 5.0	5.2 / 5.9
Energy Label	Cooling			A++	A++	A++	A++
(A+++ to D Scale)	Heating	(Average / Warmer)		A+ / A+++	A+ / A+++	A+ / A+++	A+ / A+++
Annual Energy	Cooling		kWh	149	195	293	377
Consumption	Heating	(Average / Warmer)	kWh	840 / 659	840 / 878	1,330 / 1,373	1,820 / 1,620
Sound Pressure*	Cooling	S / L / M / H	dB(A)	28 / 32 / 35 / 40	29 / 33 / 37 / 42	35 / 36 / 41 / 48	38 / 41 / 47 / 50
	Heating	L / M / H	dB(A)	32 / 36 / 40	32 / 36 / 40	36 / 41 / 47	37 / 42 / 48
Sound Power	Cooling		dB(A)	54	55	60	63
Air Flow Rate	Cooling	S / L / M / H / Max. (Power)	m ³ /min	5.6 / 6.3 / 7.0 / 8.0 / 8.8	6.0 / 6.8 / 8.2 / 9.4 / 10.3	8.0 / 8.7 / 10.5 / 12.6 / 14.0	14.4 / 15.6 / 18.7 / 20.4 / 21.6
	Heating	L / M / H	m ³ /min	6.3 / 7.0 / 8.5	7.9 / 9.3 / 10.7	9.0 / 10.9 / 13.1	16.7 / 19.6 / 23.6
Dehumidification Rate			l/h	1.0	1.2	1.5	1.8
Running Current	Cooling	Min. / Rated / Max.	A	1.2 / 4.6 / 8.0	1.2 / 4.8 / 7.4	1.7 / 8.1 / 12.0	2.0 / 9.6 / 12.8
	Heating	Min. / Rated / Max.	A	1.2 / 4.1 / 9.0	1.3 / 4.3 / 6.5	1.7 / 7.0 / 13.0	2.0 / 8.6 / 13.0
Power Supply			Ø / V / Hz	1 / 220-240 / 50	1 / 220-240 / 50	1 / 220-240 / 50	1 / 220-240 / 50
Power Supply Cable			N x mm ²	3 x 1.5	3 x 1.5	3 x 1.5	3 x 1.5
Power & Transmission Cable			N x mm ²	4 x 0.75 (Including Earth)	4 x 0.75 (Including Earth)	4 x 0.75 (Including Earth)	4 x 0.75 (Including Earth)
Dimension			mm	777 x 250 x 201	811 x 292 x 203	910 x 294 x 206	1,010 x 315 x 220
Net Weight			kg	7.8	8.5	9.5	11.8
OUTDOOR				W09TI.UEU	W12TI.UEU	W18TI.UEU	W24TI.UEU
Operation Range	Cooling	Min. / Max.	°C DB	-10 / 48	-10 / 48	-10 / 48	-10 / 48
	Heating	Min. / Max.	°C DB	-10 / 24	-10 / 24	-10 / 24	-10 / 24
Sound Pressure*	Cooling / Heating	High	dB(A)	54 / 52	54 / 54	55 / 55	58 / 60
Sound Power	Cooling	High	dB(A)	64	65	65	68
Air Flow Rate		High	m ³ /min	28.3	28.3	34	39
Piping	Liquid (ODU / IDU)	Min. / Max.	m	3 / 15	3 / 15	3 / 15	3 / 15
	Elevation (ODU / IDU)	Min. / Max.	m	10	10	10	10
Piping Connection	Liquid	OD (Outside)	mm (inch)	6.35 (1/4)	6.35 (1/4)	6.35 (1/4)	6.35 (1/4)
	Gas	OD (Outside)	mm (inch)	9.52 (3/8)	9.52 (3/8)	9.52 (3/8)	12.7 (1/2)
Drain Hose Size		OD (Outside)	mm (inch)	19.0 (3/4)	19.0 (3/4)	19.0 (3/4)	19.0 (3/4)
Refrigerant	Type			R32	R32	R32	R32
	Charge at 7.5m		kg	0.570	0.540	1.000	1.000
	Additional Charge		t-CO ₂ eq	0.385	0.365	0.675	0.675
	GWP			15	15	25	16
Compressor Type				Single Rotary	Single Rotary	Single Rotary	Single Rotary
Net Weight			kg	22.0	22.0	30.0	38.0
Dimension			mm	787 x 498 x 290	787 x 498 x 290	863 x 602 x 349	927 x 699 x 380
ACCESSORIES & OTHERS							
Multi Compatible				-	-	-	-
PI 485				-	-	-	-
Dry Contact				-	-	-	-
Wired Remote Controller				-	-	-	-

* : Sound Pressure is not a value declared on Eurovent Program.
 ※ This product contains Fluorinated greenhouse gases (R32).
 ※ S : Sleep / L : Low / M : Medium / H : High
 ※ GWP : Global warming potential
 ※ t-CO₂eq : F-gas(kg)*GWP/1000
 ※ For our policy of continuous product improvement, specification, design and feature are subject to change without prior notice.
 ※ Y : Available or Applied / - : Not Available or Not Applied

A09GA2.NSE / A12GA2.NSE / A09GA1.NSE / A12GA1.NSE

(Unit : mm)

ITEM NO.	PART NAME	REMARK
1	Inlet Grille	
2	Signal Receiver	
3	Front Grille	
4	Knockout Hole	For Pipe and Cable

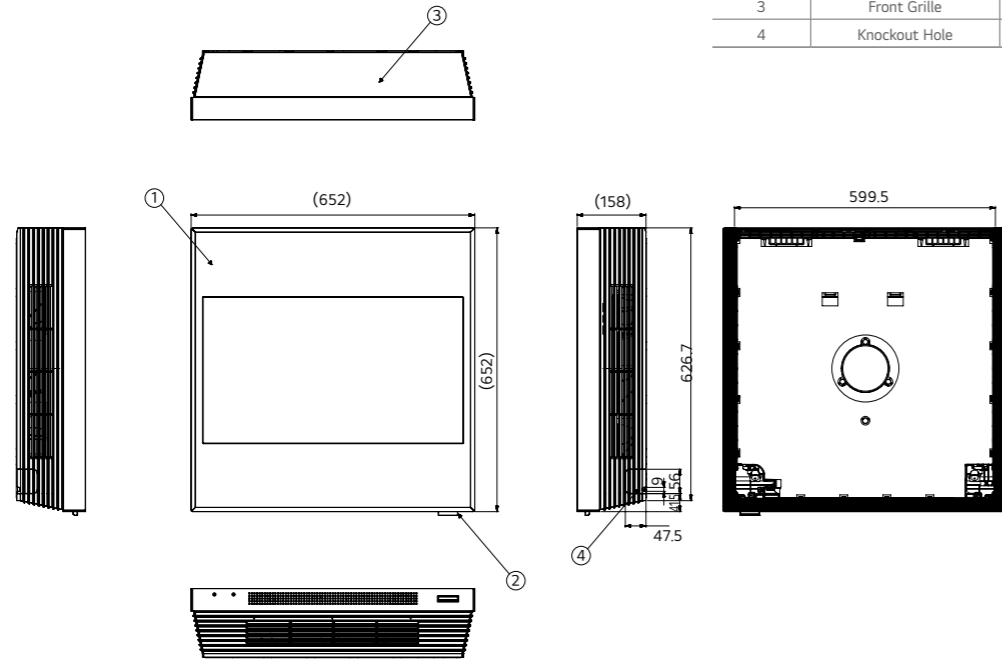

AC18BK.NSK / AC24BK.NSK / AB18BK.NSK / AB24BK.NSK

(Unit : mm)

ITEM NO.	PART NAME	REMARK
1	Front Panel	
2	Display & Signal Receiver	
3	Air Suction Filter	
4	Installation Plate	

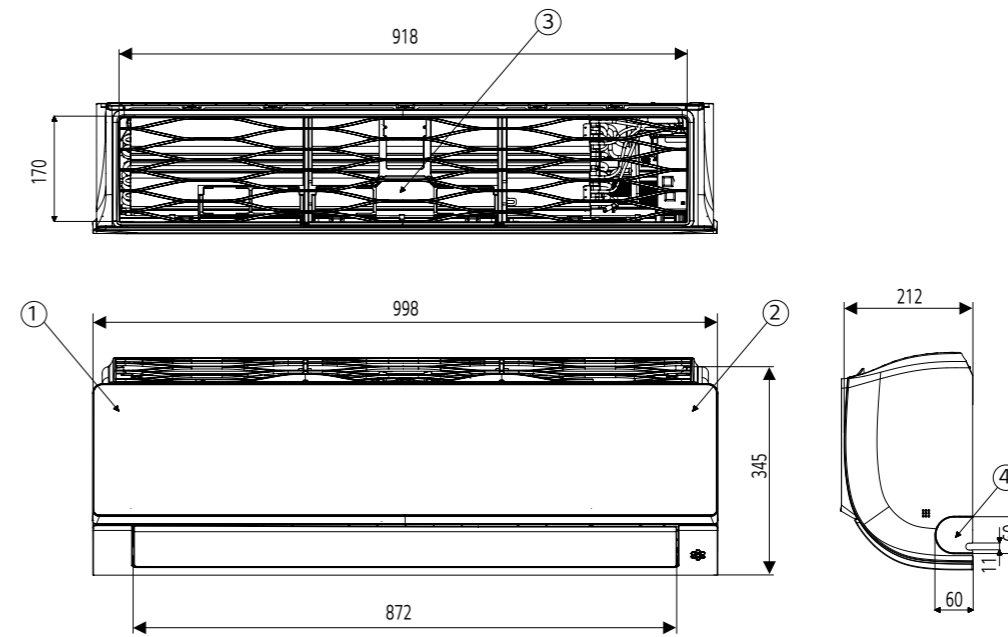

AC09BK.NSJ / AC12BK.NSJ / AB09BK.NSJ / AB12BK.NSJ

(Unit : mm)

ITEM NO.	PART NAME	REMARK
1	Front Panel	
2	Display & Signal Receiver	
3	Air Filter	
4	Knockout Hole	For Pipe and Cable

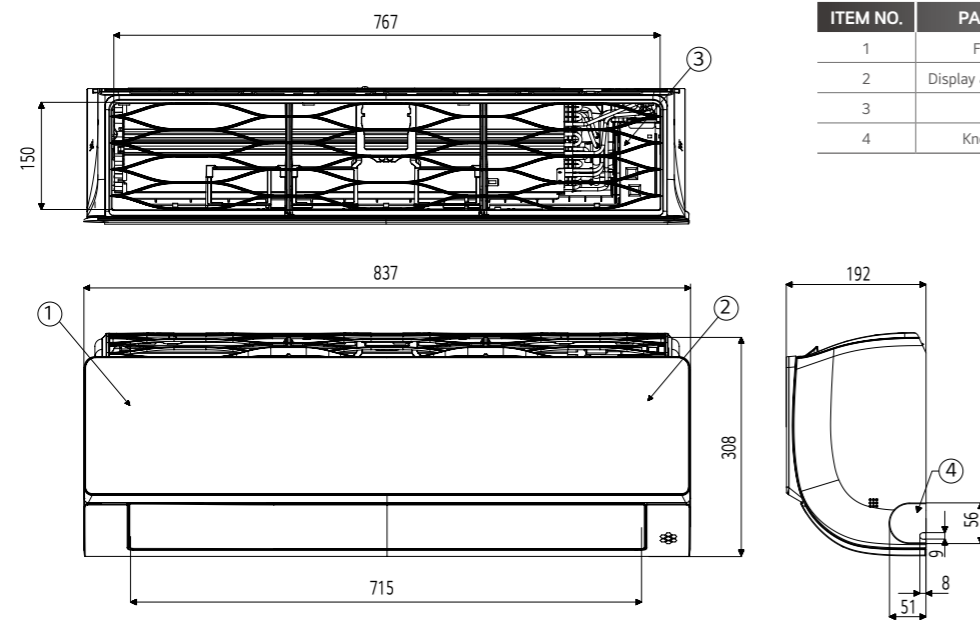

F09MT.NSM / F12MT.NSM

(Unit : mm)

ITEM NO.	PART NAME	REMARK
1	Front Panel	
2	Air Suction Grille	
3	Knockout Hole	For Pipe and Cable

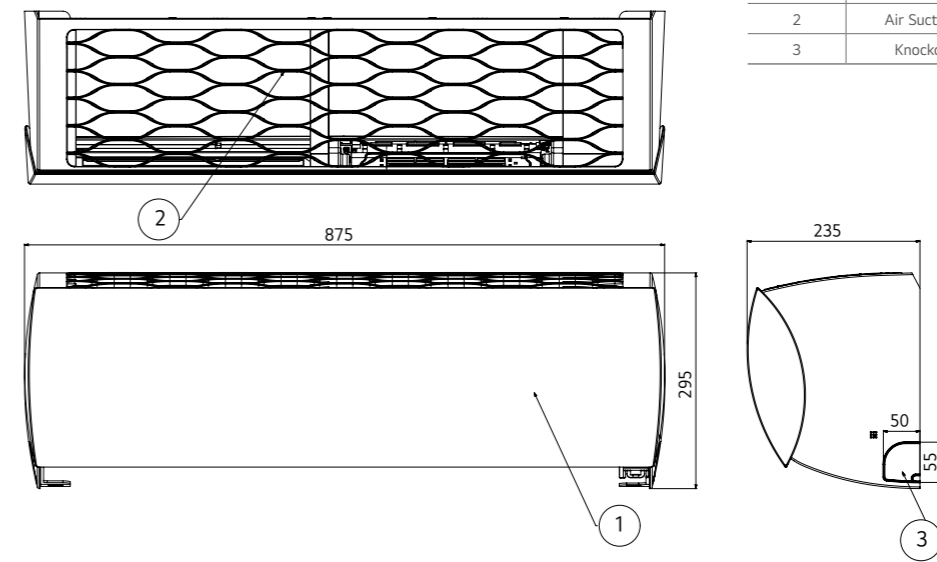

H09S1P.NS1 / H12S1P.NS1 / H09S1D.NS1 / H12S1D.NS1

(Unit : mm)

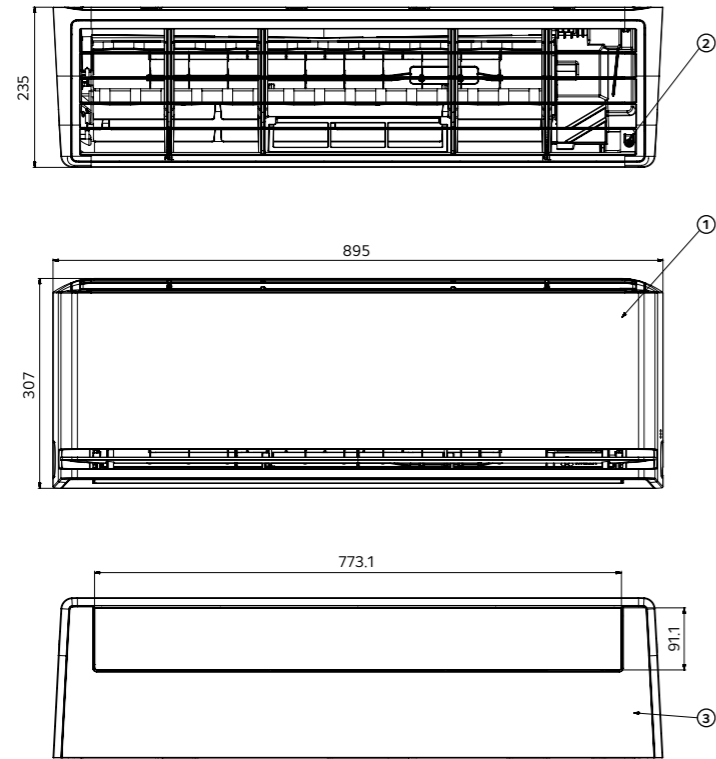

ITEM NO.	PART NAME	REMARK
1	Front Grill	
2	Filter Air	
3	Decor	
4	Knockout Hole	

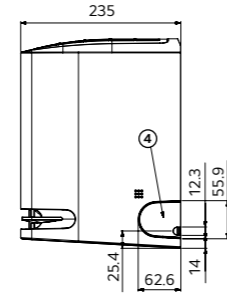

HC12RK.NSK / DC18RK.NSK / DC24RK.NSK / PC18SK.NSK / PC24SK.NSK
S18EQ.NSK / S24EQ.NSK / S18ET.NSK / S24ET.NSK

(Unit : mm)

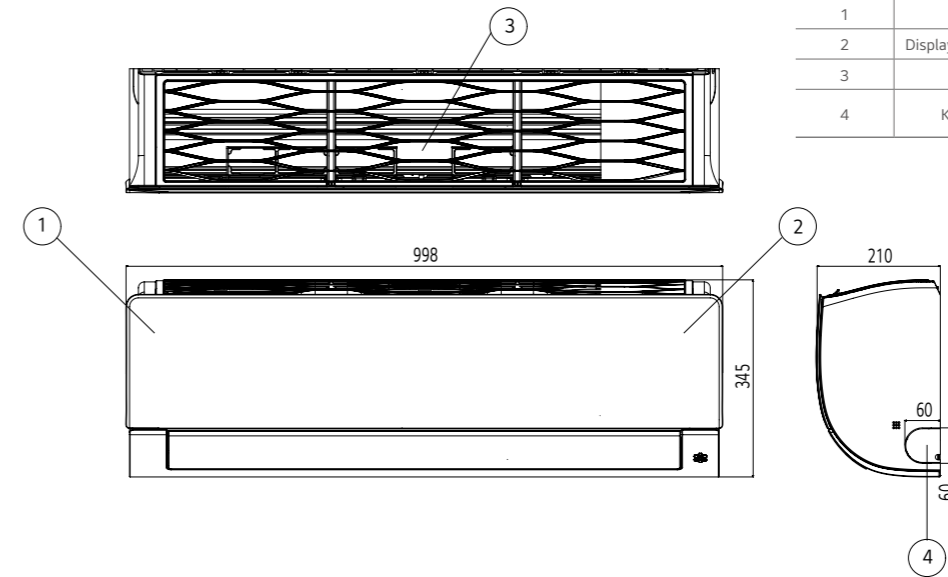

ITEM NO.	PART NAME	REMARK
1	Front Panel	
2	Display & Signal Receiver	Hidden
3	Air Filter	
4	Knockout Hole	For Pipe and Cable

HC09RK.NSJ / DC09RK.NSJ / DC12RK.NSJ / DC09RT.NSJ / DC12RT.NSJ / PC09SK.NSJ
PC12SK.NSJ / S09EQ.NSJ / S12EQ.NSJ / S09ET.NSJ / S12ET.NSJ

(Unit : mm)

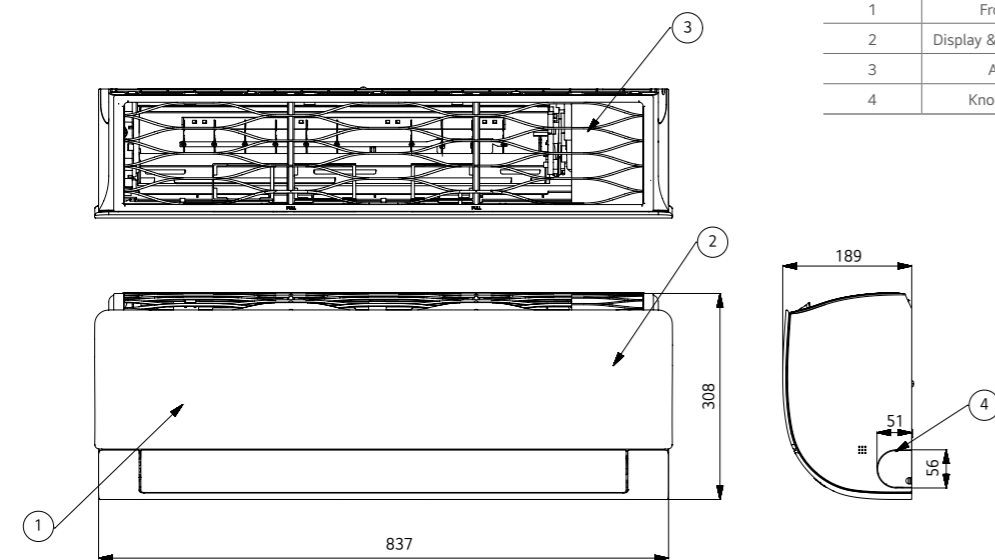

ITEM NO.	PART NAME	REMARK
1	Front Panel	
2	Display & Signal Receiver	Hidden
3	Air Filter	
4	Knockout Hole	For Pipe and Cable

W09TE.NEU

(Unit : mm)

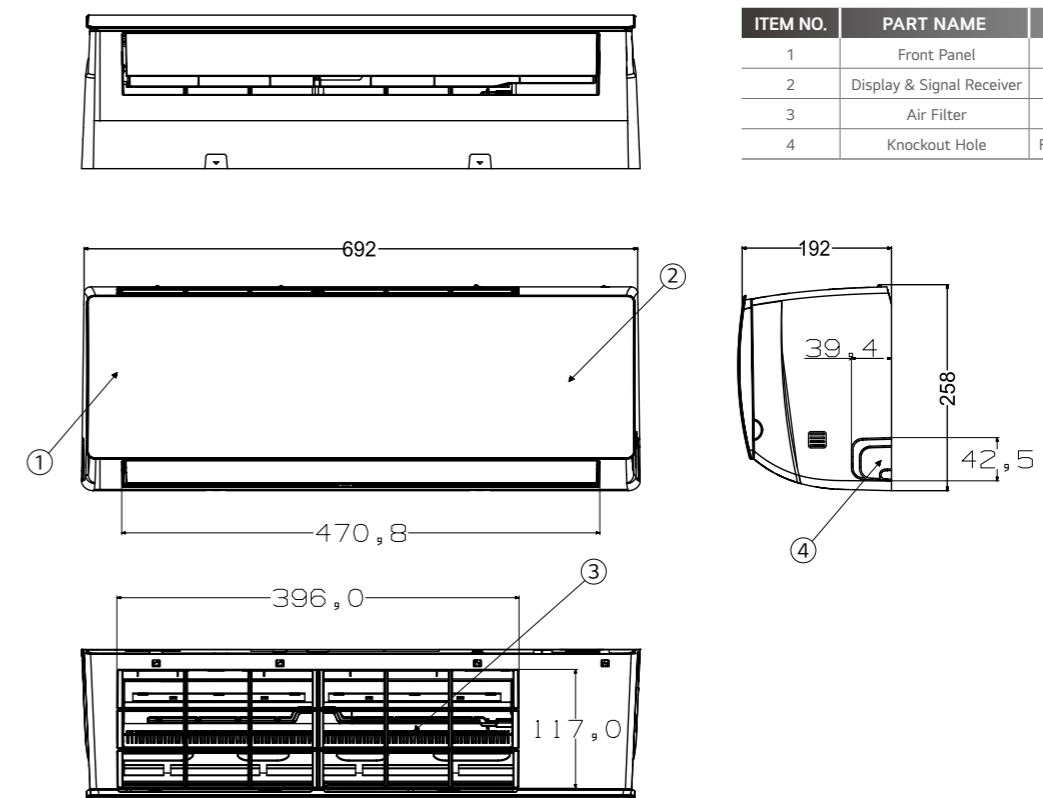

ITEM NO.	PART NAME	REMARK
1	Front Panel	
2	Display & Signal Receiver	Hidden
3	Air Filter	
4	Knockout Hole	For Pipe and Cable

W09TI.NEU / W12TE.NEU

(Unit : mm)

ITEM NO.	PART NAME	REMARK
1	Front Panel	
2	Display & Signal Receiver	Hidden
3	Air Filter	
4	Knockout Hole	For Pipe and Cable

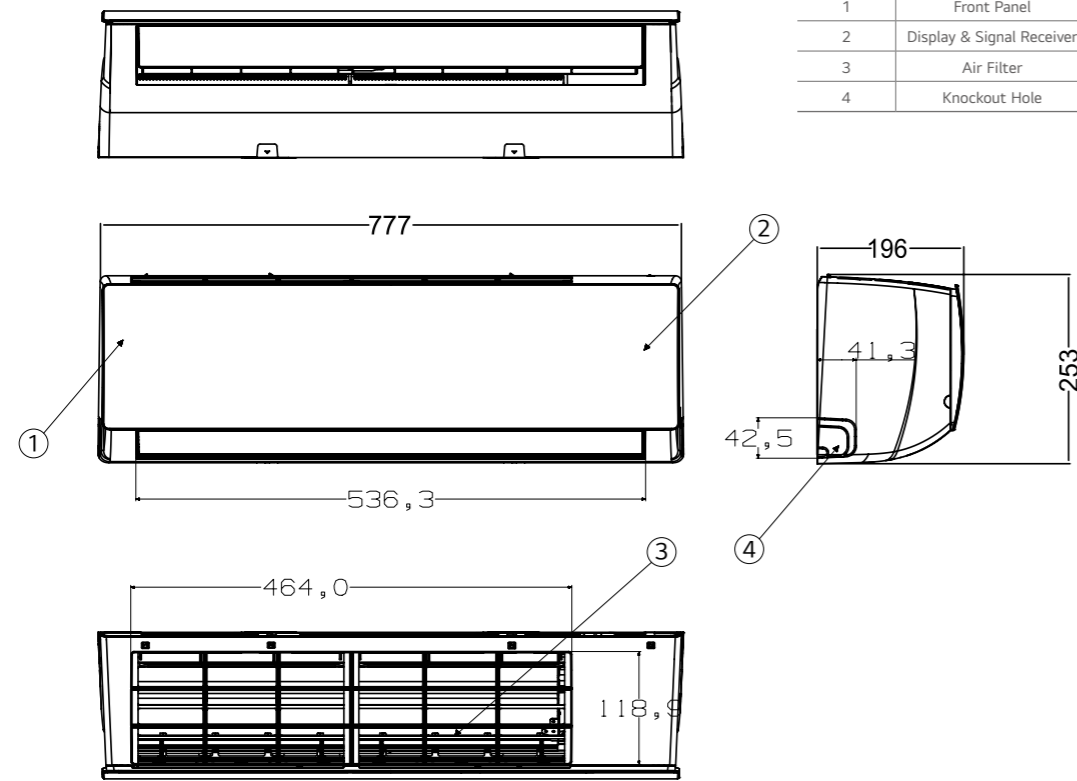

W18TI.NEU

(Unit : mm)

ITEM NO.	PART NAME	REMARK
1	Front Panel	
2	Display & Signal Receiver	Hidden
3	Air Filter	
4	Knockout Hole	For Pipe and Cable

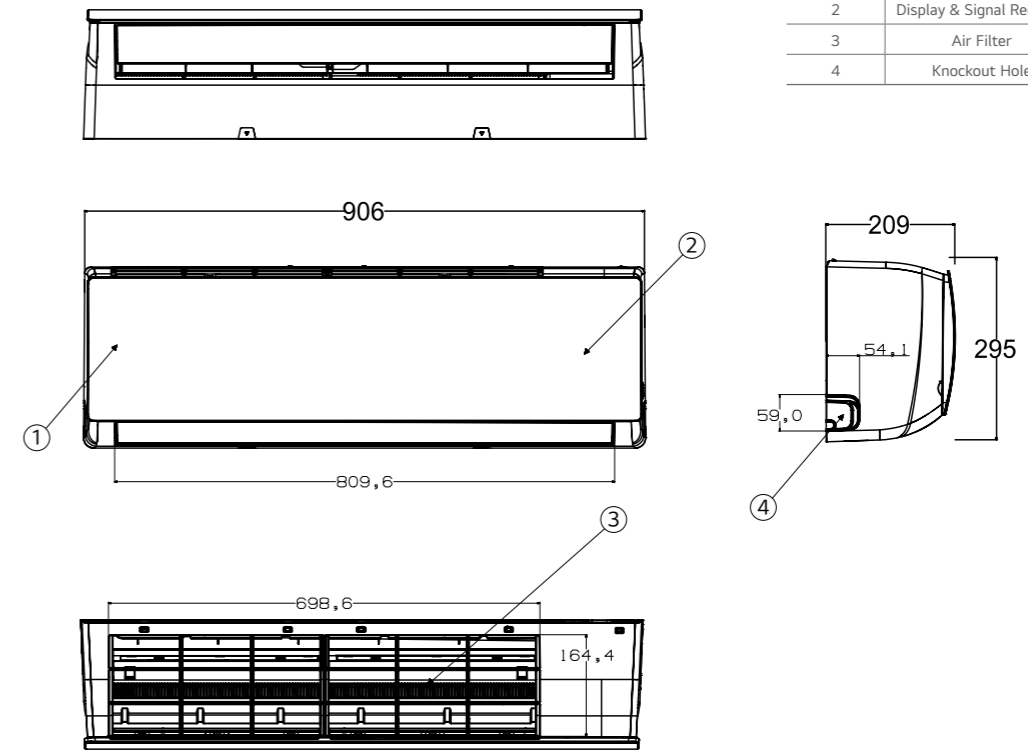

W12TI.NEU

(Unit : mm)

ITEM NO.	PART NAME	REMARK
1	Front Panel	
2	Display & Signal Receiver	Hidden
3	Air Filter	
4	Knockout Hole	For Pipe and Cable

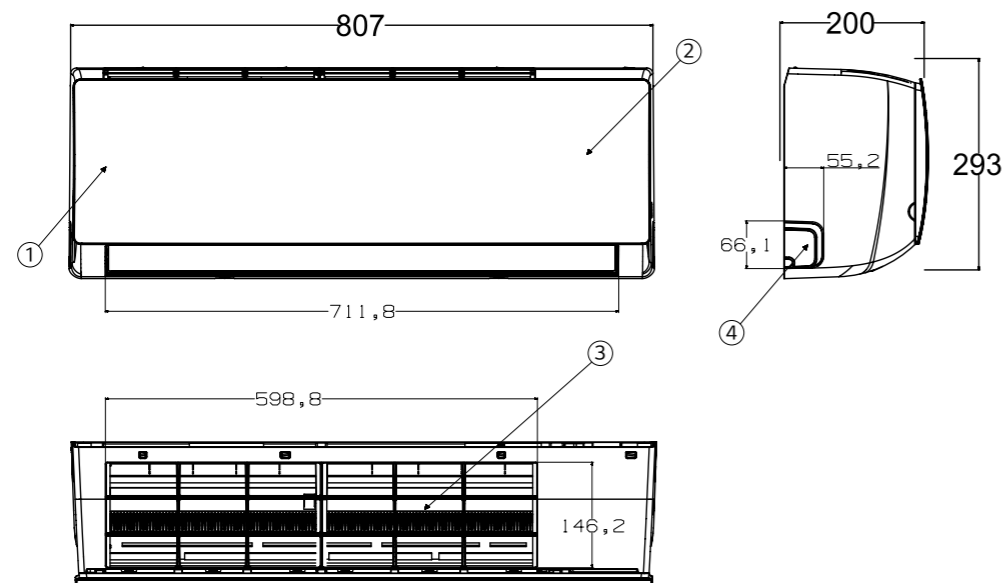

W24TI.NEU

(Unit : mm)

ITEM NO.	PART NAME	REMARK
1	Front Panel	
2	Display & Signal Receiver	Hidden
3	Air Filter	
4	Knockout Hole	For Pipe and Cable

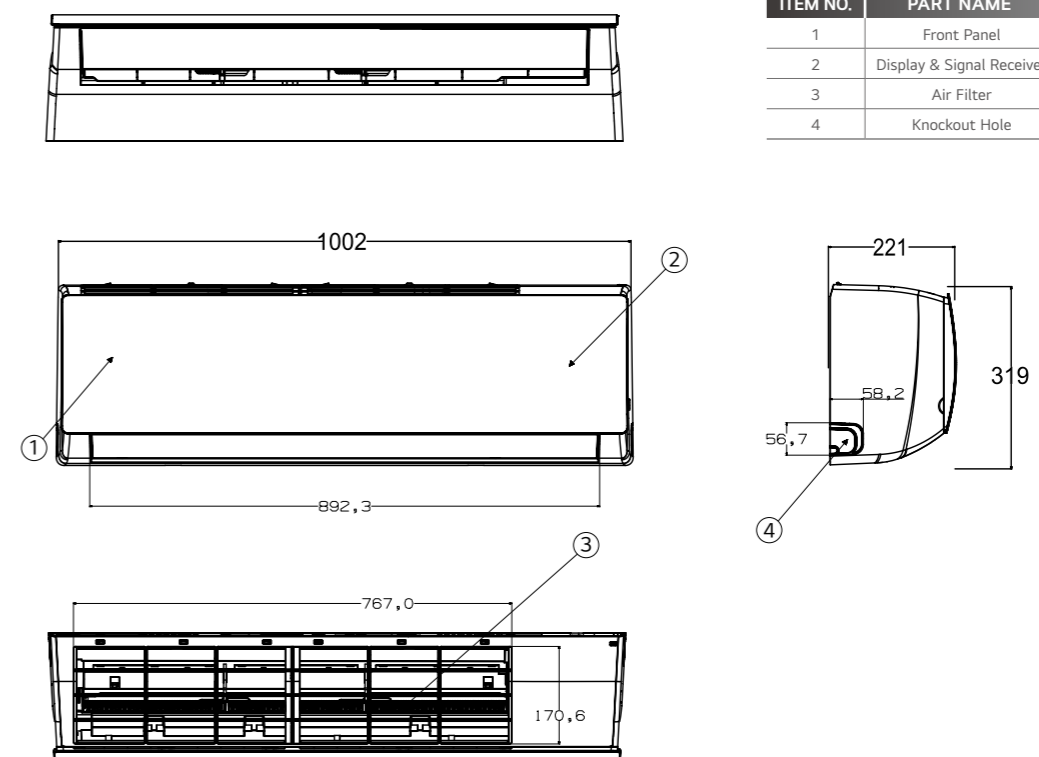

A09GA2.U18 / A12GA2.U18 / A09GA1.U18 / A12GA1.U18
H09S1P.U18 / H12S1P.U18 / H18S1D.U18

(Unit: mm)

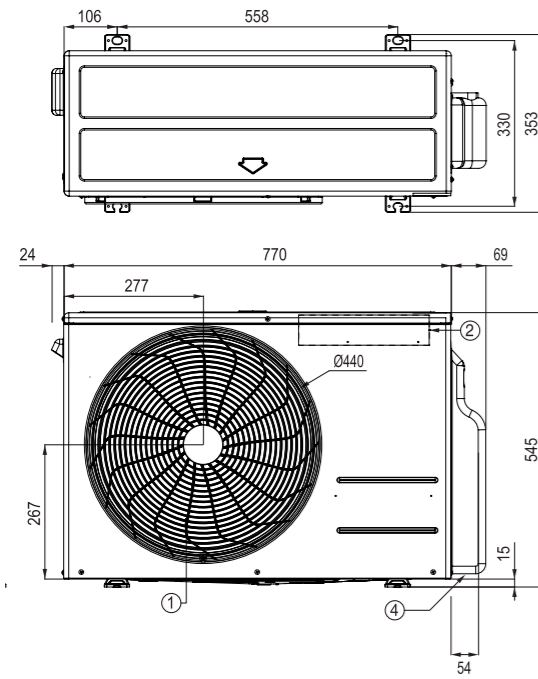

ITEM NO.	PART NAME
1	Air Outlet
2	Control Box
3	Power and Communication Cable Hole
4	Service Valve Cover
5	Gas Pipe Connection
6	Liquid Pipe Connection

A09FT.UL2 / A12FT.UL2 / HC09RK.UL2 / HC12RK.UL2 / DC09RK.UL2 / DC12RK.UL2
AC18BK.UL2 / AB18BK.UL2 / DC18RK.UL2 / PC18SK.UL2 / S18EQ.UL2 / S18ET.UL2

(Unit: mm)

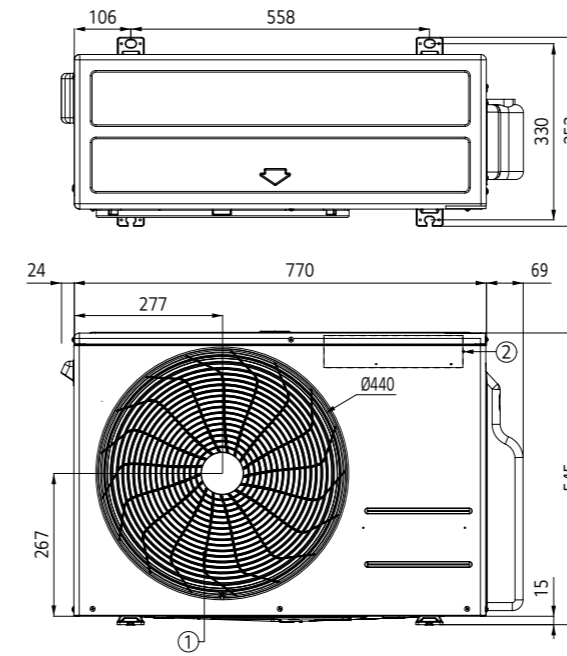

ITEM NO.	PART NAME
1	Air Outlet
2	Control Box
3	Power and Communication Cable Hole
4	Service Valve Cover
5	Gas Pipe Connection
6	Liquid Pipe Connection

AC09BK.UA3 / AC12BK.UA3 / AB09BK.UA3 / AB12BK.UA3 / H09S1D.U12 / H12S1D.U12
DC09RT.UA3 / DC12RT.UA3 / PC09SK.UA3 / PC12SK.UA3
S09EQ.UA3 / S12EQ.UA3 / S09ET.UA3 / S12ET.UA3
AP09RK.UA3 / AP12RK.UA3

(Unit: mm)

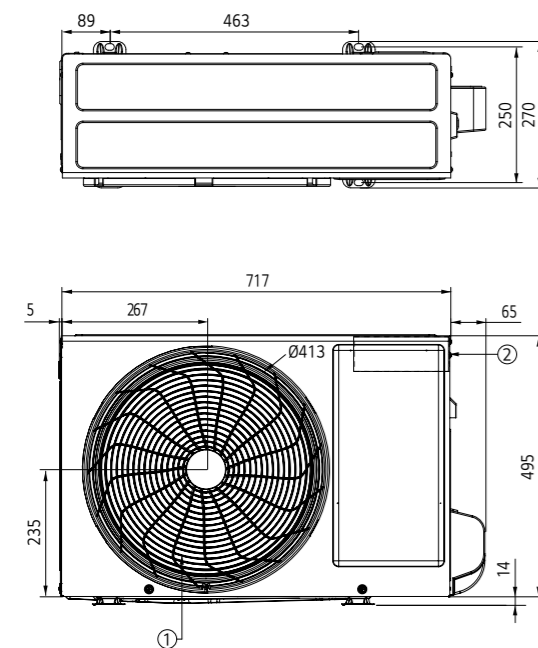

ITEM NO.	PART NAME
1	Air Outlet
2	Control Box
3	Power and Communication Cable Hole
4	Service Valve Cover
5	Gas Pipe Connection
6	Liquid Pipe Connection

F09MT.U24 / F12MT.U24 / AC24BK.U24 / AB24BK.U24 / DC24RK.U24 / H24S1D.U24
PC24SK.U24 / S24EQ.U24 / S24ET.U24

(Unit: mm)

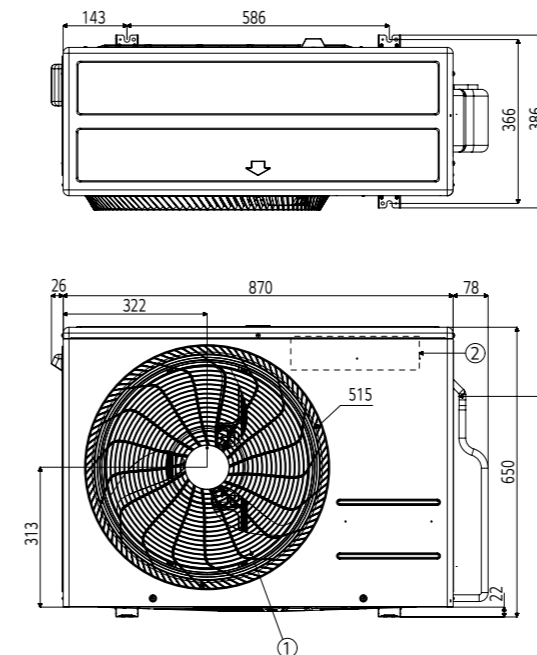

ITEM NO.	PART NAME
1	Air Outlet
2	Control Box
3	Power and Communication Cable Hole
4	Service Valve Cover
5	Gas Pipe Connection
6	Liquid Pipe Connection

W09TE.UEU / W12TE.UEU

(Unit: mm)

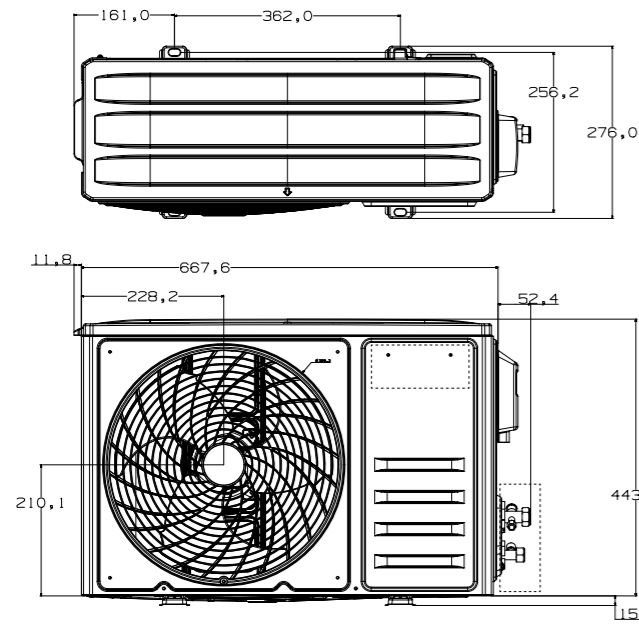

ITEM NO.	PART NAME
1	Air Outlet
2	Control Box
3	Power and Communication Cable Hole
4	Service Valve Cover
5	Gas Pipe Connection
6	Liquid Pipe Connection

W12TI.UEU

(Unit: mm)

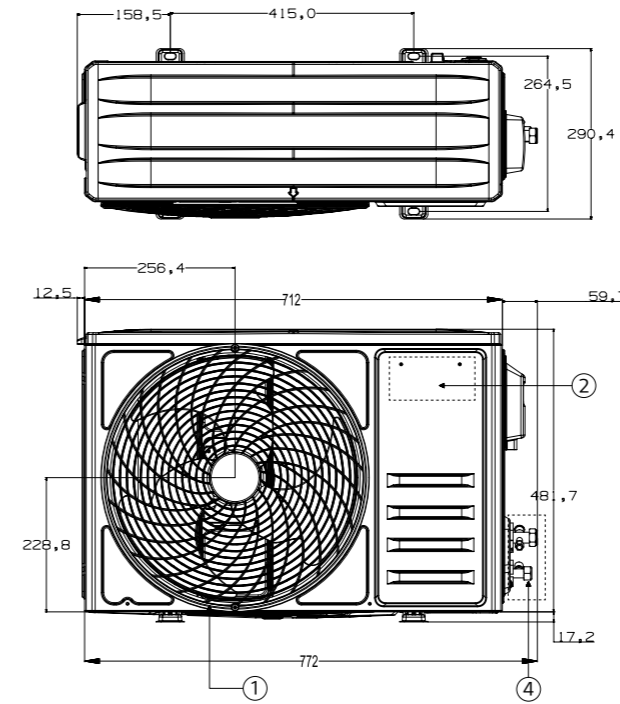

ITEM NO.	PART NAME
1	Air Outlet
2	Control Box
3	Power and Communication Cable Hole
4	Service Valve Cover
5	Gas Pipe Connection
6	Liquid Pipe Connection

W09TI.UEU

(Unit: mm)

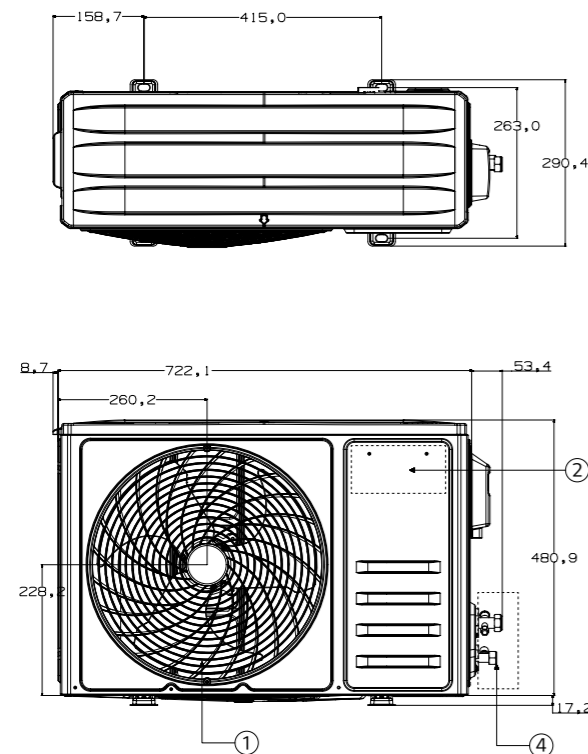

ITEM NO.	PART NAME
1	Air Outlet
2	Control Box
3	Power and Communication Cable Hole
4	Service Valve Cover
5	Gas Pipe Connection
6	Liquid Pipe Connection

W18TI.UEU

(Unit: mm)

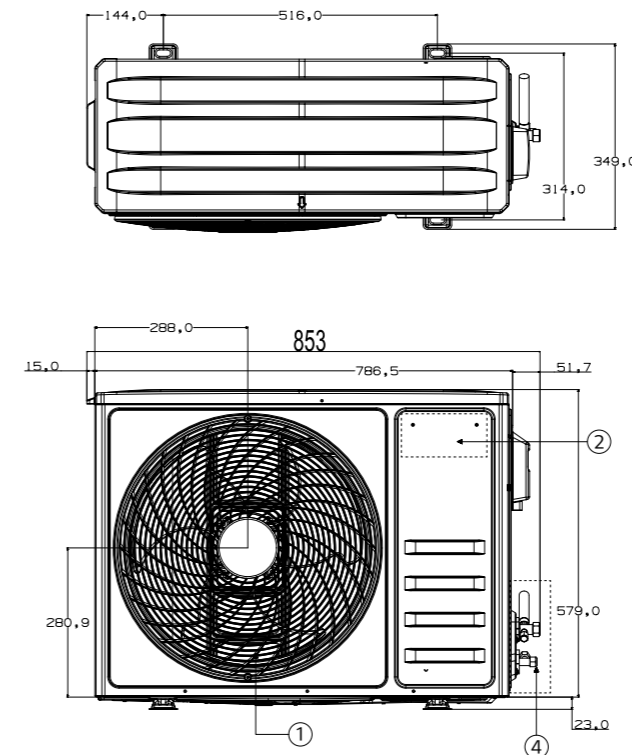

ITEM NO.	PART NAME
1	Air Outlet
2	Control Box
3	Power and Communication Cable Hole
4	Service Valve Cover
5	Gas Pipe Connection
6	Liquid Pipe Connection

		ARTCOOL			DUALCOOL								
		Gallery Premium	Gallery Special	Mirror	Prestige	Premium	Deluxe	Special DC1	Special DC2	Special PC	Special ET	Special EQ	Pro
Wired Remote Controller	5k												
	7k												
	9k	Y	Y	Y	Y	Y	Y	Y	Y	Y	Y	-	-
	12k	Y	Y	Y	Y	Y	Y	Y	Y	Y	Y	-	-
	15k												
	18k			Y				Y		Y	Y	-	-
PI 485	24k			Y			Y		Y	Y	-	-	
	5k												
	7k												
	9k	Y	Y	-	-	Y	-	Y	Y	-	-	-	-
	12k	Y	Y	-	-	Y	-	Y	Y	-	-	-	-
	15k												
Dry Contact	18k			-			Y		-	-	-	-	
	24k			-			Y		-	-	-	-	
	5k												
	7k												
	9k	Y	Y	Y	Y	Y	Y	Y	Y	Y	Y	-	-
	12k	Y	Y	Y	Y	Y	Y	Y	Y	Y	Y	-	-
Dry Contact	15k												
	18k			Y			Y		Y	Y	-	-	
	24k			Y			Y		Y	Y	-	-	

* Y : Available
 * When connected to Multi 14k & 16k Outdoor units, this may not be supported.

Standard Wired Remote Controller



Standard III
PREMTB101

Standard III
PREMTBB11



Standard II
PREMTB001

Standard II
PREMTBB01

Model Name	PREMTB101 PREMTBB11	PREMTB001 PREMTBB01
Operation Mode	On / Off, Fan Speed Control, Temperature Setting	
Mode Change	Cooling, Heating, Auto, Dehumidification, Fan	
Auto Swing / Vane Control	•	•
Reservation	Simple, Sleep, On / Off, Weekly, Holiday	
Time Display	•	•
Electrical Failure Compensation	•	•
Child Lock	•	•
Operation Status LED	•	•
Indoor Temperature Display	•	•
Wireless Remote Controller Receiver	-	•
Size (W x H x D, mm)	120 x 120 x 16	120 x 121 x 16
Backlight	•	•
Display AirQuality Status	-	-

* Refer to each model PDB for applicable models.

PI 485

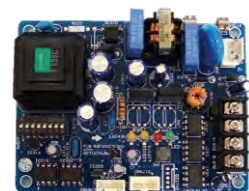

PMNFP14A1

Power : Single phase AC 220V 50/60Hz
 Max. no of the indoor units that can be connected : 64 Units
 Model applied : RAC / Multi / Single / THERMA V
 * Refer to each product PDB for applicable models.

Dry Contact



PDRYCB000

PDRYCB400



PDRYCB320

PDRYCB500 /
PDRYCB510*

* Refer to each product PDB for applicable models.
 * No case for PDRYCB510

Model	PDRYCB000	PDRYCB400	PDRYCB320	PDRYCB500 / PDRYCB510*
Contact Point	1 Control Point	2 Control Point	8 Control Point	Modbus RTU
Power Input	AC 220V from outside power source	DC 5V & 12V from indoor unit PCB	DC 5V & 12V from indoor unit PCB	DC 5V & 12V from indoor unit PDB
Voltage / Non Voltage Input	-	•	•	-
On / Off Control	•	•	•	•
Lock / Unlock	-	•	-	-
Fan Speed Setting	-	-	•	•
Thermo Off	-	•	•	-
Energy Saving	-	•	-	-
Temperature Setting	-	•	•	•
Error Monitoring	•	•	•	•
Operation Monitoring	•	•	•	•

Remote Controller



DUALCOOL Prestige
 DUALCOOL DC1
 DUALCOOL DC2
 DUALCOOL PC
 DUALCOOL EQ
 DUALCOOL ET

Button	Display Screen	Description
	-	To turn on / off the air conditioner.
	88°C	To adjust the desired room temperature in cooling, heating or auto changeover mode.
COMFORT AIR	-	To adjust the air flow to indirect wind.
LIGHT OFF	-	To set the brightness of the display on the indoor unit.
MODE		To select the cooling mode.
		To select the heating mode.
		To select the dehumidification mode.
		To select the fan mode.
FAN SPEED		To select the auto changeover / auto operation mode.
		To adjust the fan speed.
ENERGY CTRL.	-	To bring the effect of the power saving.
JET MODE	P0	To change room temperature quickly.
ROOM TEMP		To adjust the air flow direction vertically or horizontally.
		To display the room temperature.
°C ↔ °F[5sec]	°C/°F	To change unit between °C and °F.
SET/ CANCEL	-	To set / cancel the functions and timer.
	-	To adjust time.
	-	To turn on / off air conditioner automatically.
	-	To cancel the timer settings.

* Remote Controller specifications may vary for each model.
 * Remote Controller specification, design and feature are subject to change without prior notice.

Remote Controller



DUALCOOL Pro

Button	Display Screen	Description
Dual Sensing		To set or cancel dual sensing mode operation.
	-	To turn on / off the air conditioner.
Light Off	-	To turn On/Off the air conditioner indoor display.
Mode		To select the cooling mode.
		To select the auto changeover/auto operation mode.
		To select the dry mode.
		To select the heating mode.
		To select the fan mode.
Fan Speed		To adjust the fan speed.
Energy Saving		To minimize power consumption.
Jet Mode		To change room temperature quickly.
		To adjust the desired room temperature in cooling, heating or auto mode. (16°C ~ 31°C)
Swing		To adjust the air flow direction vertically.
Swing		To adjust the air flow direction horizontally. (Optional)
Room Temp.		To display the room temperature.
Sleep		To set the sleeping mode automatically.
Func.		The Ion generator uses millions of ions to help improve indoor air quality. (Optional)
		To remove moisture generated inside the indoor unit.
Timer		To turn on/off air conditioner automatically at desired time.
Set/Cancel	-	To set/cancel the special functions and timer.
	-	To adjust time.
°C/°F (5 s)		To change unit between °C and °F



DUALCOOL Premium
DUALCOOL Deluxe

Button	Description
	Power Turns the appliance on or off. Connecting to LG ThinQ Press Power button to prepare the status for connecting appliance and wi-fi.
	Mode Selects the desired operation mode. • Each press changes the modes in this order: Cooling → Auto → Dehumidification → Heating → Fan
	Soft Air Keep you cool without feeling a draft.
	Temperature ^ v Adjusts the desired room temperature.
	Fan Speed + - Adjust the fan speed.
	Up-Down Swing Adjusts the airflow direction up and down.
	Cleaning Mode While the remote control and appliance turned off, press and hold the button for about 5 seconds to fix the vane for cleaning the vane easily.
	Jet Mode Changes the room temperature quickly.
	Energy Control Decrease the power input. You can control energy consumption.
	Exit (3 s) When entering the settings, press and hold the button for about 3 seconds to return the previous setting.
	Function Selects the desired function.
	Air Purify Supplies clean, fresh air using ion particles.
	Indoor Temperature (3 s) Press and hold the button for about 3 seconds to displays the room temperature.
	Reset Resets the wireless remote control setting.

Remote Controller

ARTCOOL
Gallery PremiumARTCOOL
Gallery Special

Image	Description
	<p>Power Turns the appliance on or off.</p> <p>Connecting to LG ThinQ Prepare the status for connecting product and wi-fi by pressing and holding the Power button for 3 seconds.</p>
	<p>Mode Selects the desired operating mode such as cooling, auto, dehumidification, heating, or fan, or connects the product and remote control.</p> <ul style="list-style-type: none"> Each press changes the mode in this order: Cooling → Auto → Dehumidification → Heating → Fan Connect the product and remote control by pressing and holding the button for 3 seconds.
	<p>Sleep Sets sleep mode to help you sleep better.</p> <ul style="list-style-type: none"> Sleep reservation starts from 30 minutes and can be set in hourly increments up to 12 hours.
	<p>Display Premium only Turns the product's screen on, off, or changes it.</p> <ul style="list-style-type: none"> Each time you press the Display button, the product screen changes in the order of cover screen ? home screen. Turn the product's screen on or off by pressing and holding the button for 3 seconds.
	<p>Energy/Jet Sets Power Saving, Smart Care, Cool Power, or sets to Comfort Air.</p> <ul style="list-style-type: none"> Each time you press the Energy/Jet button, the mode changes in order of Power Saving ? Smart Care ? Cool Power ? Cooling. Turn indirect wind On or Off by pressing and holding the Energy/Jet button for 3 seconds.
	<p>Temperature </p> <p>Adjust the desired temperature by pressing the button on the remote control.</p> <ul style="list-style-type: none"> The desired temperature can be set between 18°C and 30°C for cooling mode. The desired temperature can be set between 16°C and 30°C for heating mode.
	<p>Fan Speed </p> <p>Adjusts the fan speed</p> <ul style="list-style-type: none"> The fan speed can be set in order of 1 ↔ 2 ↔ 3 ↔ 4 ↔ 5 ↔ natural wind.
	<p>Comfort Special only Adjust in the way that no air comes out of the air outlet at the bottom of the product so that it is not directly hit by air.</p>
	<p>< > Special only Move left and right for using the Setting.</p>
	<p>Pointer Premium only Checks or sets various functions on the product screen using the remote control.</p>
	<p>Sound Volume - Premium only Reduces or turns off the notification sound that notifies you when you set up or change product features.</p>
	<p>Sound Volume + Premium only Turns on or increases the notification sound that notifies you when you set up or change product features.</p>
	<p></p> <p>Sets Ionizer, AI drying, heat exchanger cleaning, sleep, on and off timer, or cancels all reservations, smart diagnosis, and status indicator.</p>
	<p>Reset Resets the wireless remote control setting. Open the remote control battery cover and then press the Reset button to reset it.</p>
	<p>Premium only If the product system operates slowly or freezes while using the product, or if the product suddenly turns off, you can restart the product.</p> <ul style="list-style-type: none"> Press and hold the button and the button on the remote control at the same time for 3 seconds.

Image	Description
Ionizer	Ion particles from Ionizer reduce the surface bacteria and other harmful substances.
AI Drying	Moisture remaining in the heat exchanger can be removed by operating the product in a blowing state for a certain period of time.
Sleep	<p>Sets sleep mode to help you sleep better.</p> <ul style="list-style-type: none"> Sleep mode starts from 30 minutes and can be set in hourly increments up to 12 hours
On Timer	<p>Schedules the product to turn on.</p> <ul style="list-style-type: none"> For On Timer, you can set the desired time in 1-hour increments from 1 hour to 24 hours.
Off Timer	<p>Schedules the product to turn off.</p> <ul style="list-style-type: none"> For Off Timer, you can set the desired time in 1-hour increments from 1 hour to 24 hours.
Cancel Entire Reservation	Cancels all reserved features.
Smart Diagnosis	Diagnoses the cause of product failure.
Status Indicator	<p>Special only Turns on and off the LED light which is located on the lower right side of the product.</p>

NOTE

- Depending on the remote control's Bluetooth connection status, the screen that appears on the remote control display may vary.
- When you turn the remote control off and on again, the last used settings will appear on the remote control display.
- Depending on the model, the remote control display may differ from the image in the owner's manual.
- Available features may vary depending on the model.

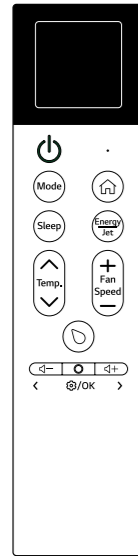
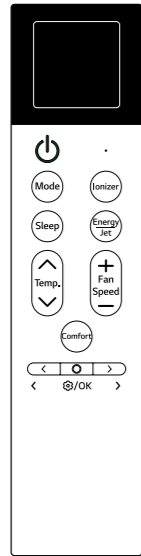
VENTILATION



Clean Air Supply

Remove Up to 99.99% of Harmful Particles on Pre-Filter with UVnano

UVnano™
UVnano is a compound word of UV (ultraviolet) LED which reduces harmful bacteria, and nanometer which is the UV wavelength unit.

TÜV Rheinland

UVnano Technology Applied

It Prevents 99.99 % of Bacteria and Viruses from Growing

Easy Filter Maintenance

Via the one-touch button, the user can open the access door at the bottom of the unit, pull down the heat exchanger to change the filters. It is easy and simple without the need for any additional tools.

One Touch Button

Filter Handle

After pressing the one-touch button, unhook the safety hooks that holds door from failing to fully open the door.

Hold the filter handle and pull it out down.

Smart Control

① Dual Laser Fine Dust Sensor

Two fine dust sensors monitor the incoming air and the supplied air to the room in real time to ensure that clean air is always supplied.

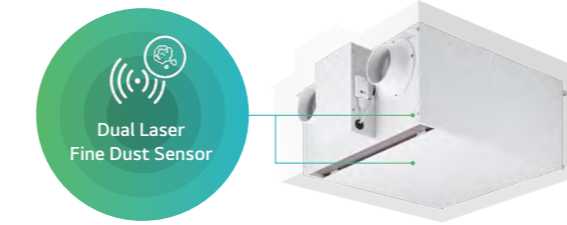

When the measured dust concentration in the air supplied to the room is higher than the pre-set value, a notification or text message will be sent out for filter replacement.

* Wi-Fi Modem is Optional.

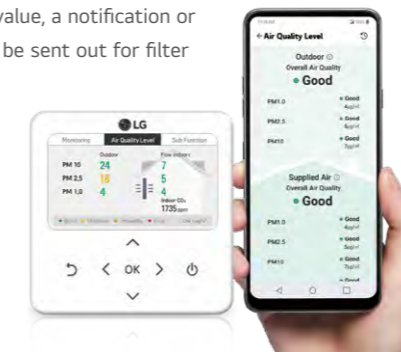

② CO₂ Monitoring

The embedded CO₂ sensor monitors the carbon dioxide concentration in the room in real time and automatically controls the ventilation rate.

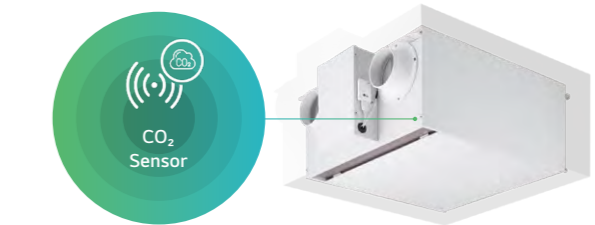

The system monitors the CO₂ concentration in the room and adjusts the ventilation rate accordingly. When the CO₂ concentration is high, it increases the ventilation rate, and automatically reduces it when the concentration is low.

* Wi-Fi Modem is Optional.

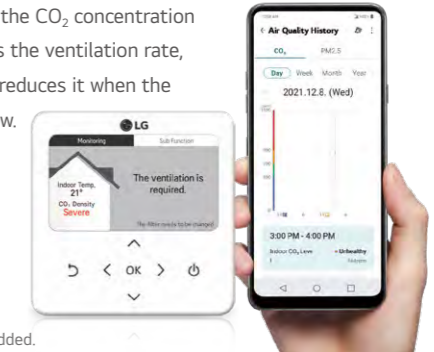

* CO₂ Sensor is Embedded.

③ Control ERV Anytime, Anywhere

Wired Remote Control	Mobile	Third-Party Compatibility
<ul style="list-style-type: none"> - Indoor CO₂ concentration - Dust concentration in the supply air - Dust concentration in outdoor air 	<p>Check and control the Indoor air conditioner anytime, anywhere</p>	<p>With the dry contact connected, Modbus protocol is available.</p>

* To use 3rd party wall pad, please contact Sales Engineer.

④ Filter Maintenance Alarm

The filter replacement notification and text message are sent when the fine dust concentration is higher than the pre-set point.

When Should the Filter be Replaced?

Replace the fine dust filter in ERV.

Replace the fine dust filter in the ventilation.

Vent
Turn off after 45min
Bypass >

CO₂ Good

Supplied Air Quality: Good
Overall Outdoor Air Quality: Good
Indoor Temperature: HIGH

LZ-H015GBA6 / LZ-H020GBA6



MODEL				LZ-H015GBA6	LZ-H020GBA6	
Dimensions (W x H x D)	Body	mm		640 x 320 x 640	640 x 320 x 640	
	Weight	kg		23	23	
Power Supply		Ø / V / Hz		1 / 230 / 50	1 / 230 / 50	
ERV Mode	Operating Step			SH / H / L	SH / H / L	
	Current	SH / H / L A		0.43 / 0.38 / 0.23	0.59 / 0.51 / 0.26	
	Power Input	SH / H / L W		56 / 49 / 26	79 / 71 / 30	
	Air Flow	SH / H / L CMH		150 / 150 / 80	200 / 200 / 100	
	External Static Pressure	SH / H / L Pa		100 / 70 / 50	100 / 70 / 50	
	Temperature Exchange Efficiency	Heating (SH / H / L) (ErP)	%		85	82
		Heating (SH / H / L) (JIS)	%		80 / 80 / 84	78 / 78 / 82
		Cooling (SH / H / L) (JIS)	%		74 / 74 / 83	70 / 70 / 81
	Enthalpy Exchange Efficiency	Heating (SH / H / L) (JIS)	%		79 / 79 / 83	75 / 75 / 81
		Cooling (SH / H / L) (JIS)	%		74 / 74 / 80	68 / 68 / 76
Energy Label	A+ to G Scale			A	A	
Sound Power Level	SH / H / L dB(A)			53 / 51 / 45	55 / 53 / 46	
Sound Pressure Level	SH / H / L dB(A)			28 / 26 / 21	30 / 28 / 22	
Bypass Mode	Current	SH / H / L A		0.45 / 0.40 / 0.26	0.60 / 0.52 / 0.29	
	Power Input	SH / H / L W		63 / 53 / 31	84 / 73 / 35	
	Air Flow	SH / H / L CMH		150 / 150 / 80	200 / 200 / 100	
External Static Pressure	SH / H / L Pa			100 / 70 / 50	100 / 70 / 50	
Operation Range	Outdoor Air Temperature / Relative Humidity	°C / %		-10 - 40 / 20 - 80	-10 - 40 / 20 - 80	
Duct Work	Qty	EA		4	4	
	Size (Ø)	mm		125	125	
Fan Motor	Supply Air Fan	RPM		1,850 / 1,710 / 1,300	2,050 / 1,910 / 1,400	
	Exhaust Air Fan	RPM		1,750 / 1,600 / 1,250	1,910 / 1,770 / 1,320	
	Max.	RPM		2,100	2100	
	Min.	RPM		1,000	1,000	
Filters	Grade ¹⁾	-		ePM, 95%	ePM, 95%	
	Size (W x H x D)	mm		278 x 276 x 50	278 x 276 x 50	

Note :
 1. Cooling Capacity Test condition - Indoor temperature : 27°C DB, 19°C WB / Outdoor temperature : 35°C DB
 2. Heating Capacity Test condition - Indoor temperature : 20°C DB / Outdoor temperature : 7°C DB, 6°C WB
 3. Humidifying capacity is based on the following conditions - Indoor temperature : 20°C DB, 15°C WB / Outdoor temperature : 7°C DB, 6°C WB
 4. Cooling and heating capacities are based on the following conditions. : Fan is based on High and Super-high.
 5. The operating sound measured at the point 1.5 m below the center of the unit is converted to that measured at an anechoic chamber.
 6. The specifications, designs and information here are subject to change without notice.

LZ-H015GBA6 / LZ-H020GBA6



Accessories

CHASSIS	LZ-H015GBA6	LZ-H020GBA6
CO ₂ Sensor		Embedded
UVnano		Embedded
Pre Filter (Washable)		Embedded
Dual Laser Fine Dust Sensor		Embedded
Remote Controller (PREMTB101 / PREMTBB11)		○
Wi-Fi Modem (PWFMD200)		○

※ ○ : Applied, - : Not applied
 Option : Refer to model name in table

Functions

MODEL	LZ-H015GBA6	LZ-H020GBA6
Air Purification	UVnano	○
	Pre-Filter	○
	Fine Filter (ePM, 95%)	○
Reliability	Self Diagnosis	○
	Auto Restart	○
	Child Lock*	○
	Forced Operation	○
	Group Control*	○
Convenience	Turn On / Off Reservation	○
	Schedule*	○
	Night Silent Cooling Operation	○
	Delayed Operation	○
	Airflow Amount Customized Operation	○
	Seasonal Customized Operation	○
	Seasonal Auto Operation	○
Installation	E.S.P. Control*	○
	Central Control (LGAP)	○
ETC	Filter Alarm	○
	CO ₂ Sensor	○
	Wi-Fi	Accessory

Note
 1. ○ : Applied, X : Not applied
 Accessory : Ordered and purchased separately the accessory package referring to the model name provided and install at field.
 Accessory line-ups varies by region, so check your local catalogue or local sales material.
 2. Some functions can be limited by remote controller.
 3. * : These functions need to connect the wired remote controller